

DECEMBER, 1936

# RADIO RETAILING

McGRAW-HILL PUBLISHING COMPANY, INC.

25 CENTS PER COPY

*For Christmas Gift Sales*

Push the RCA Victor Line—and enjoy  
*Greater Profits!*

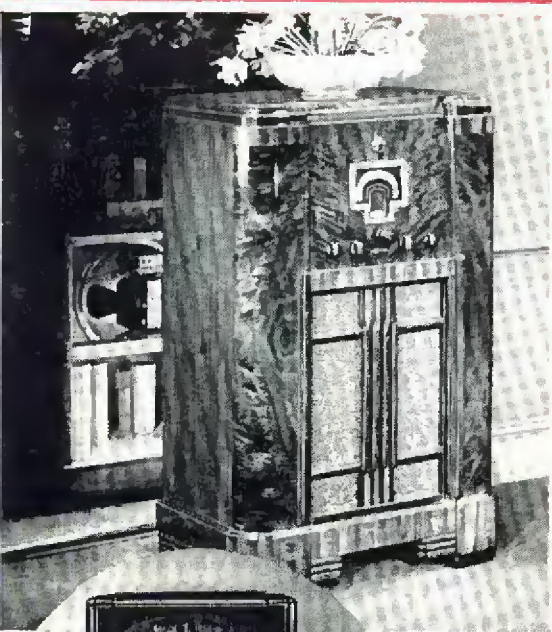

### Magic Voice Series

• Model 9K-2, console with Magic Voice, Magic Brain, Magic Eye, RCA Metal Tubes, 9-tube, 5-band superheterodyne. Foreign, domestic, police, aviation, amateur, U. S. weather reports. Phonograph connection and 13 other important features.

**\$129.95**

(*f. o. b. Camden, N. J.*)



RCA VICTOR gives dealers real money-makers to sell for Christmas gifts! A complete price range—with ace sets in every bracket from \$20 to \$600... 28 sets under \$100... 24 outstanding quality features for easy selling, led by the famous

### RCA VICTOR MAGIC QUARTETTE

*Magic Voice • Magic Brain • Magic Eye • Metal Tubes!*

GET your share of the Christmas set sales. Reap a harvest of Yuletide profits by selling RCA Victor's great 1937 radios!

Just look at the matchless RCA Victor models! That's exactly what they are—matchless—in quality, performance and price! There are 24 great features that mark them outstanding. These features make RCA Victor radios easy to sell! They mean quality! They mean

performance! That's why you should talk features to your prospects.

And the line is priced to cover all important price brackets. From \$20 to \$600—with 28 models under \$100! Plenty of high unit profits! Plenty of mass market profits! Feature RCA Victor—and make money!

*Listen to "The Magic Key" every Sunday, 3 to 3 P. M., E. S. T., on the NBC Blue Network.*

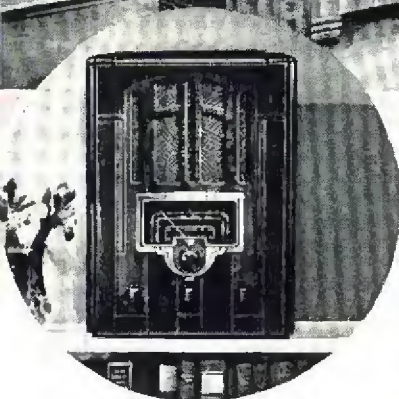

### Extra Value Series

• 6T-2—In this attractive cabinet, you find a superb chassis, which brings in U. S. and foreign programs, police calls, airports, amateurs. Other improvements, too, including Metal Tubes.

**\$49.95**



# RCA Victor

RCA Manufacturing Company, Inc., Camden, New Jersey  
A SERVICE OF THE RADIO CORPORATION OF AMERICA





## What will Mallory-Yaxley do next?

No wonder *YOU* Service Men keep asking this question. Every time Mallory-Yaxley has done something, it has been of tremendous help to *YOU*.

Mallory-Yaxley gave *YOU* the first complete Replacement Volume Control Manual ever printed, and the first really *SILENT* Replacement Volume Control in radio history.

Mallory-Yaxley gave *YOU* sixty-nine Replacement Condensers that meet the needs of thousands and provided a Condenser Manual that saved hours of work in servicing.

Mallory-Yaxley provided a mere handful of Replacement Vibrators to render service to over three million automobile radios, and the Mallory Vibrator Manual is *YOUR* Automobile Radio Encyclopedia.

What will Mallory-Yaxley do next ???

Next month, the question will be answered.

Coming !!! The "Big News" of 1937!

The biggest help you ever had.

Coming !!!

Use  
**P. R. MALLORY & CO. Inc.**  
**MALLORY**  
 REPLACEMENT  
 CONDENSERS...VIBRATORS

**P. R. MALLORY & CO., Inc.**  
 INDIANAPOLIS INDIANA  
 Cable Address—Palmallo

Use  
**YAXLEY**  
 REPLACEMENT  
 VOLUME CONTROLS

# RADIO RETAILING

DECEMBER, 1936

## In This Issue

O. FRED. ROST Editor  
 W. MacDONALD, Managing Editor  
 C. A. NUEBLING, Technical Editor  
 T. H. PURINTON, Assistant Editor  
 HARRY PHILLIPS, Art Director  
 •  
 RAY V. SUTLIFFE, Consulting Editor  
 •  
 Tom Blackburn Chicago George Tenney San Francisco  
 H. S. Knowlton Boston  
 •  
 HOWARD EHRlich, Vice-President  
 H. W. MATEER, Manager

### McGraw-Hill Publishing Company, Inc.

Publication Office  
 99-129 North Broadway, Albany, N. Y.  
 Editorial and Executive Offices  
 330 West 42nd Street, New York, N. Y.

Cable Address: MCGRAWHILL, New York.  
 Member A.B.P. Member A.B.C.

James H. McGraw, Jr. Chairman  
 Malcolm Muir President  
 James H. McGraw Honorary Chairman  
 Howard Ehrlich Vice-President  
 B. R. Putnam Treasurer  
 D. C. McGraw Secretary

RADIO RETAILING, December, 1936, Vol. 21, No. 12. Published monthly, price 25c copy. Subscription rates—United States and Central and South American countries \$1. All other countries \$2 a year or eight shillings. Printed in U. S. A. Entered as Second Class Matter, September 8, 1936, at Post Office, Albany, N. Y., under the Act of March 3, 1879. Cable address "McGrawhill, New York." Member of A.B.P. Member of A.B.C. Copyright 1936 by McGraw-Hill Publishing Co., Inc., 330 West 42d Street, New York, N. Y.

Branch Offices: 520 North Michigan Ave., Chicago; 883 Mission St., San Francisco; Aldwych House, Aldwych, London, W.C. 2; Washington; Philadelphia; Cleveland; Detroit; St. Louis; Boston; Atlanta, Ga.

PREMATURE PUBLICITY .....	5
THE RADIO MONTH.....By O. Fred. Rost	7
POWER COMPANIES REVIVE RADIO PROMOTION.....By W. MacDonald	8
FIGURES .....	11
SERVICE IS THE SMALL DEALER'S STRONGHOLD.....By E. T. Cunningham	12
DISPLAY—MANAGEMENT—ADVERTISING—SELLING .....	14
SOUND, THEN BUSINESSMEN DON'T TIRE.....	20
EXPLAINING THE ULTRA-HIGHS.....By C. A. Nuebling	22
MAKE THEM SING AGAIN.....	25
THIS STORK SELLS.....By I. L. Cochran	27
STORES ON WHEELS.....By Tom F. Blackburn	28
NEWS .....	31
PREVIEW OF NEW PRODUCTS.....	41
FREE HELPS .....	47
NEW ELECTRICAL APPLIANCES.....	49
CIRCUITS .....	53
OSCILLOGRAPH CIRCUITS .....	58
SHOP SHORTCUTS .....	61
ACTUAL SOCKET VOLTAGE CHART.....	65
TRICKS OF THE TRADE.....	69
LETTERS .....	72

SALES STATIC . . . . "BUT NONE OF THE NEW SETS HAVE CABINETS LIKE THIS!"





HELLO, BILL —  
*YOU* LOOK  
PROSPEROUS

SURE —  
I'M SELLING  
LABYRINTH  
RADIOS

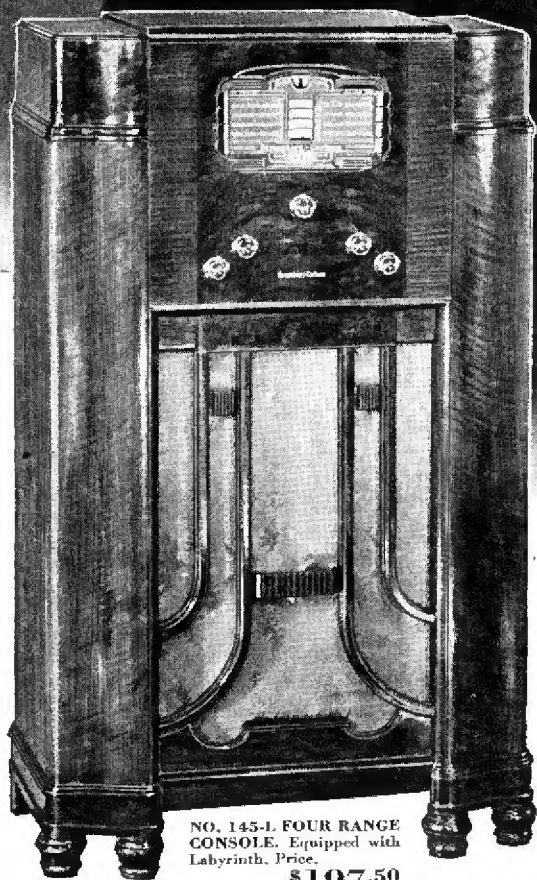

NO. 145-L FOUR RANGE  
CONSOLE. Equipped with  
Labyrinth. Price,  
\$197.50

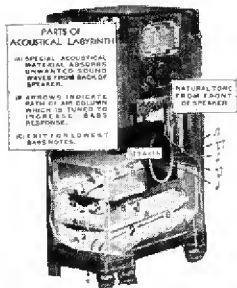

### Labyrinth RADIO

The long, winding passageway of the Acoustical Labyrinth takes the place of the usual box-like cavity in the cabinet which is the source of the exaggerated boom in low tones. It gives you deeper bass notes, with a new fidelity and increases the volume capacity and accuracy of the loud speaker.

EVERYWHERE the story is the same on Labyrinth radio—easy sales, increasing sales and the jingle of money in the pockets of the salesmen. The Acoustical Labyrinth is the Stromberg-Carlson feature that makes it possible for a demonstrator to **SHOW** why the set sounds better. It comes nearer to "selling itself" to people than any other development affecting tone, that radio has ever seen.

The Acoustical Labyrinth—every advertisement of which in the national periodicals brings a flood of consumer inquiries\*—is now available in 12 different models. One of these, a beautiful console, is priced at \$149.50.

*"There is Nothing Finer Than a Stromberg-Carlson"*

The complete line of Stromberg-Carlsons range in price from \$49.95 to \$985. (All prices slightly higher in Southeastern States and West of the Mississippi.)

STROMBERG-CARLSON TELEPHONE MFG. CO., ROCHESTER, N. Y.

\*These inquiries are sent to dealers by the factory. One enthusiastic dealer writes in that he sold four Labyrinth Radios from four inquiries.

# Stromberg-Carlson



# Simplex

## Announces New JOBBER POLICY

Effective January 1, 1937 Simplex Distributor Franchises will be restricted to established Jobbers located in the large natural trade centers. National Advertising and Radio Broadcasting Programs will tie in with this new 100% Jobber Policy.

### SEE THESE SENSATIONAL NEW VALUES

The Simplex Line is complete with attractive console models as well as the table models illustrated here.

All models can be furnished in two, six

or thirty-two volt at proportionate prices.

All models available in 2000 meters—220 volt A.C.—or A.C.-D.C.

**\$27.45**

7 Tube  
Super  
2 Band

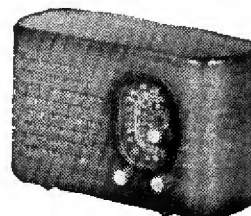
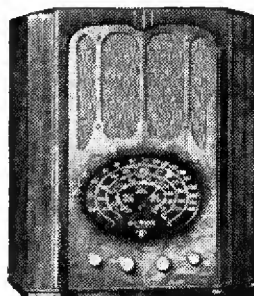
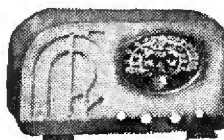

**\$19.95**

6 Tube  
Super  
2 Band

**\$36.95**

9 Tube  
Super  
3 Band

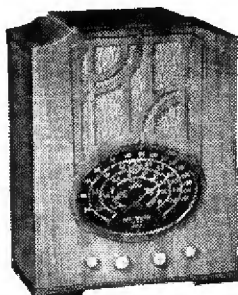

**\$49.95**

11 Tube  
Super  
3 Band

The Simplex Line has exceptional profit possibilities because of

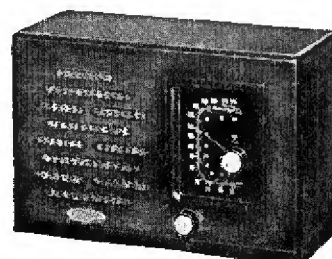

**\$12.25**

4 Tube  
T.R.F.  
1 Band

### LIBERAL DISTRIBUTOR DISCOUNTS

Your territory may be open. Wire, telephone or write for further details

## THE SIMPLEX RADIO COMPANY

Factory: SANDUSKY, OHIO



# Stewart-Warner

## DOES IT AGAIN—WITH MORE FEATURES FOR YOUR MONEY!

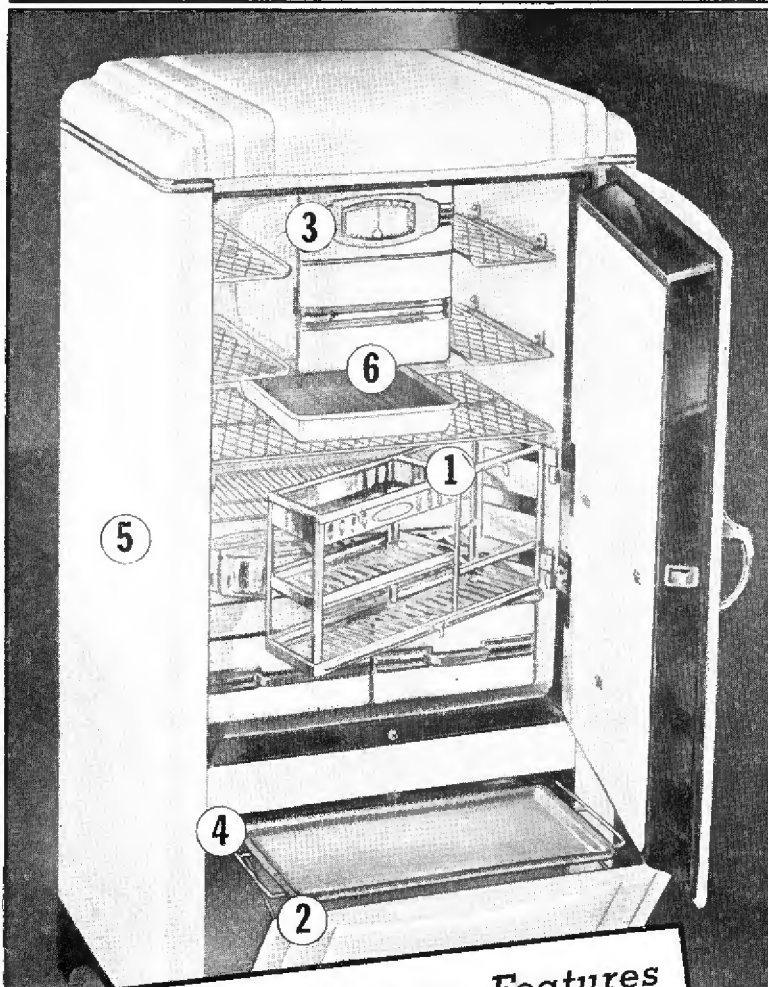

Exclusive "No-Cost"  
Floor Plan Starts  
Your Profits NOW!

YOU'LL hear it everywhere—"The new 1937 Stewart-Warner is twice as good as the one that boosted sales 127% last year!" It's your best bet for 1937 sales because it offers your customers MORE FEATURES FOR THE MONEY—it's your best bet for 1937 profits because of its amazing freedom from service troubles.

Best of all, Stewart-Warner alone offers you these three advantages that let you start selling RIGHT NOW—give you a big jump on competitors:

**1. New Floor Plan with No Finance Charges!** Stewart-Warner alone offers this brand new plan that makes it possible to install a floor showing of this marvelous line immediately—and pay nothing for finance charges!

**2. Exclusive Retail Finance Plans!** You get all the advantages of the Stewart-Warner-C.I.T. 100% Advance and Non-Recourse Finance Plan. You can feature "no money down" terms, yet have no repossession worries—and every Stewart-Warner sale is a cash sale for you. No waiting for YOUR money!

**3. Powerful Selling Helps!** Everything you need for selling is back of the 1937 line! From Horace Heidt and his famous Brigadiers on a coast-to-coast network—to handsome, attention-compelling displays for your store. . . The big chrome and blue background shown below is just one of the displays available. Let your Stewart-Warner distributor tell you how to get this display, and give you full information on the 1937 Stewart-Warner set-up!

### 32 Sales-Clinching Features Including 6 Exclusive Scoops!

Stewart-Warner Leads the Field With

- |                       |                            |
|-----------------------|----------------------------|
| 1. NEW SAV-A-STEP     | 4. SLO-CYCLE MECHANISM     |
| 2. NEW SLID-A-TRAY    | 5. VAPOR-SEALED CABINET    |
| 3. 16-POINT COLD DIAL | 6. REVERSIBLE FREEZER DOOR |

32 big features in all give you more to talk about—more to sell—make Stewart-Warner the outstanding refrigerator "buy" for 1937! MORE FEATURES give your customers MORE FOR THEIR MONEY in convenience, in economy, in dependability! And this great new refrigerator sets new standards of beauty inside as well as outside!



**STEWART-WARNER CORPORATION, CHICAGO, ILLINOIS**



## PREMATURE PUBLICITY

AFTER FIFTEEN YEARS of steady development, after surviving the gold-rush stage, after suffering all the growing pains of a century crowded into a few brief years, the radio industry today is at a point where those engaged in it may hope to "cash in" on their investment.

It seems that at such a time no one connected with the radio industry should become a party to any activities that may seriously retard its growth and prosperity.

Such would be the effect if members of the radio industry allow unwarranted enthusiasm or the mere hope for early commercial exploitation of television to interfere with their active prosecution of the duty they have toward the industry in which they make their money.

AFTER A CAREFUL SURVEY *Radio Retailing* has reached the conclusion that as of December, 1936, television *does not hold promise of reaching for several years hence* such a state of mechanical perfection, adaptability and universal usefulness as would be indispensable to its success as a commercial enterprise.

The best television receiver of today projects but a small image. Its efficiency is so limited that only those who always want to have the "first" of everything would be willing to invest several hundred dollars to own one.

While the television camera is a marvel of scientific achievement, transmission has advanced only to a point where from an elevation of 500 feet it is effective for perhaps 25 miles.

This means that today for even such small but thickly populated states as New Jersey or Massachusetts, having about 8200 square miles, it would require 50 separate broadcasting stations to obtain coverage and unless motion picture films were used or a yet undiscovered medium of inter-station transmission is invented, each of those fifty stations would have to put on its own and separate show. The cost

of all this would definitely be prohibitive.

It follows that until television transmission and reception has been perfected to a far greater point, until television programs can be offered with some degree of frequency and reliability, until the vexing problem of who is to pay the tremendous cost of providing some continuity of original programs has been solved, television cannot become a commercially sound enterprise.

THAT BEING ITS STATUS TODAY, television should not be permitted to exert an insidious influence outside the laboratory, particularly when that influence tends to weaken and undermine the prospects and prosperity of the industry which gave it birth.

Reports on progress made in the scientific development of television rightfully belong to those who support the effort but not to the public at large. Such reports are too easily misunderstood, misinterpreted and all too readily may become a tool for unscrupulous promoters.

No real good can accrue from such premature publicity.

As a matter of fact, the publicity recently given to the current state of television actually has done irreparable damage to the radio industry. Because of it thousands of consumers have postponed the purchase of radio sets in the belief that before long they will be able to buy a television set at no greater cost and it is certain that the erosive effect of that publicity on current radio sales will continue.

It is evident that the interests of the entire radio industry will be better protected and best served if no premature and sales-paralyzing publicity is released. Publicity should be withheld until the development of commercial television has advanced to a point where it is capable of fulfilling at least some of the expectations and hopes which such publicity fosters.



# Now... the "Miracle 5"

THE YEAR'S GREATEST SENSATION IN SMALL SET DESIGN AND VALUE

- 5-Tube AC Superheterodyne
- Standard American Broadcast . . . All Police Bands . . . Amateur and Aeroplane Stations
- Automatic Volume Control . . . Tone Control
- 3 Watts Output
- Emerson Micro-Selector
- Gemloid Dial . . . . .
- Dynamic Speaker . . . . .
- Hand Rubbed Two-Tone Walnut Cabinet, 12½ in. high.

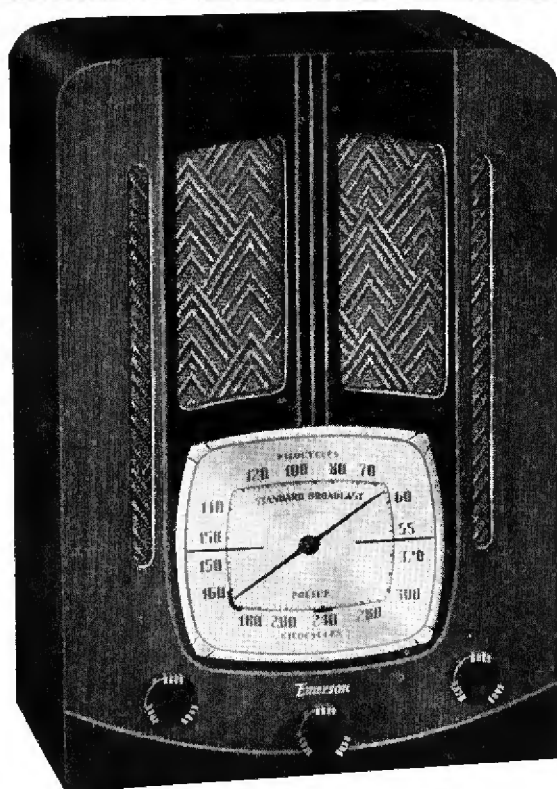

# \$17.95

Slightly Higher in West and South



EMERSON . . . Model R-152

# Emerson

"RE-CREATES THE ARTIST



# Radio

IN YOUR HOME"

Never before have so many quality features been offered at this sensational price . . . never before has PRICE meant so much in the way of STYLE, CONSTRUCTION, PERFORMANCE and BUYING INDUCEMENT to the public—and GOOD WILL to the dealer who gives such outstanding VALUE.

The New EMERSON Model R-152 . . . "Miracle 5" . . . will make selling history in YOUR store because it looks and performs like sets selling at twice the cost . . . because it gives you a substantial profit . . . because it has everything the market NEEDS for dramatic and productive merchandising.

Ask Your Nearest Emerson Distributor  
or Write or Wire Direct

30 Emerson Models from \$14.95 to \$149.95

EMERSON RADIO AND PHONOGRAPH CORPORATION • 111 Eighth Ave., New York, N. Y.  
Cable Address: EMPHONOCO, N. Y. World's Largest Maker of Small Radios



# December

1 9 3 6

## THE RADIO MONTH

### LESS SLAUGHTER

To judge by current production schedules of important radio manufacturers and the size of stocks in distributors' warehouses, it is safe to predict that even in large cities the ensuing post-holiday season will see fewer cut price sales than in many years.

One large producer has worked out a system in cooperation with his distributors by which the sets coming off his production line in December actually were already on order from dealers. Another maker who ordinarily gears production to within four weeks of dealer demand cuts that gap in half during November and December so that he cannot possibly be caught with an oversupply of any one model when the year ends. Other production control plans are in operation and distributors are keeping their stocks stripped down. There will be few distress stocks and little dumping. Price slaughter, therefore, is most likely to be indulged in by high pressure retail outlets that use the loss-leader system of baiting the public.

### RURAL PARALYZATION

The sales of battery radio sets are being seriously retarded and in some territories actually paralyzed by the false hopes for early electrification of all rural areas. Radio manufacturers, distributors and dealers should obtain authentic information on current plans, know which areas are involved and make it their business to dispense accurate knowledge on this subject.

Electrification can come only in territories where returns from the sale of current may be expected to warrant the huge investment that is required to build the power lines. In some sections it will not come for years, in sparsely

settled territories never. To disillusion the public by giving the facts will release much pent-up business.

### OFF THE RECORD

Big sales during 1936 have whet the appetites of radio set manufacturers for even bigger ones in 1937 and some of them seem convinced that they can boost their own share of sales by beating their competitors "to the gun" with earlier launchings of the new models.

Basically, set makers are substantially in agreement that new lines should not be brought out until late May or early June. But—what with new conditions, greater prosperity, new trade practice rules and old scores to settle, we have seen several lines of new models, all finished, ready to be put into production, but their manufacturers hope that they will not be forced to spring them earlier than in May. Yet the premature announcement of competitive lines would force their hand. For the industry as a whole, it would seem better if all set makers would "hold their horses"—until May or June.

### MAIL-ORDER MADNESS

Mail-order wholesalers, widely criticized and in some instances even boycotted when they distribute net price catalogs indiscriminately to dealer and consumer alike had, we thought, long since learned their lesson . . . until the end of November, when a large eastern outfit had the temerity to smear the words "Buy Wholesale" across the pages of a daily newspaper, openly offering a well-known tube line at 50 and 10 off list.

Questioned concerning the tube cut,

the manufacturer whose wares were slashed furnished the amazing information that this mail-order house is definitely not one of his distributors, obtained the tubes through some underground channel for the express purpose of using them as price-cut leaders.

Flagrant flouting of the dealer's interests, such as this, make things tough for other mail-order distributors, most of whom now carefully avoid upsetting the applecart.

### SALES BOOSTING

Two important factors in boosting radio set and service sales, the National Broadcasting Co. and the Columbia Broadcasting System, piled up new records in October, 1936. NBC took in nearly \$2,700,000 or 21 per cent more than in any previous month and CBS beat October 1935 by 42.7 per cent with billings of \$2,754,000. That makes a total of nearly \$5,500,000 spent in a single month with those two agencies for the privilege of "going on the air." That money bought programs which wide-awake dealers advertise and dramatize because programs are the "gas" that makes radio sets "run" and the more they are "run" the bigger are the chances for selling new sets, tubes, replacement parts and service.



EDITOR

# POWER COMPANIES REVIVE RADIO PROMOTION

By  
W. MacDonald



**T**HE "Forgotten Appliance" . . . As such we call *radio* to the attention of power companies. For, unlike many home electrical devices promoted liberally, even lavishly, by utilities because of their potential load-building characteristics, radio has steadily added kilowatts to the lines, asking little supporting effort in return.

Installed radios now outnumber any other appliance, with the exception of flat-irons. If all sets were good sets, in proper working order, the total power used could be second only to

refrigerators. If every receiver was used just one hour more per day the resulting increase in load would amount to over \$31,000,000 in a single year. And when radio is used . . . lights stay on . . . the house is kept warm . . . and drinks kept cold . . . adding additional load.

Obviously a lusty infant capable of paddling its own promotional canoe through years of unprecedented growth, radio has had little help from the Utilities. Now, however, there is evidence in the news that many central stations are beginning to realize

that if radio could do what it has done, on its own, radio could likewise make even more striking advances as a load-builder if given a helping-hand.

Utility interest in radio, willingness to help dealers promote it, will, in our estimation, be one of the major trends of the new year. And to the trade, where such aid clearly avoids meddling with established distribution methods (more of this later), it will be welcome and unexpected manna.

#### *Bright Spots In The News*

In the November number of *Radio Retailing* we reported the second-set drive instituted by the Birmingham (Ala.) Electric Company, in which the town was literally plastered with signs redounding to the benefit of all radio retailers.

Now we have even more detailed news from New England.



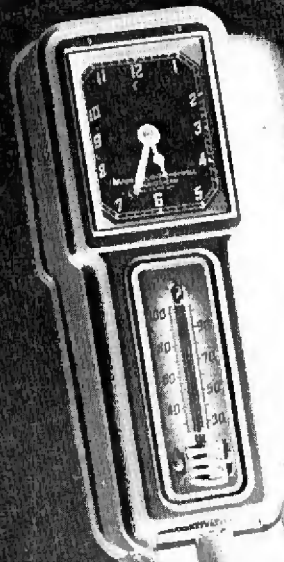

The **HOUSE** is kept warm..

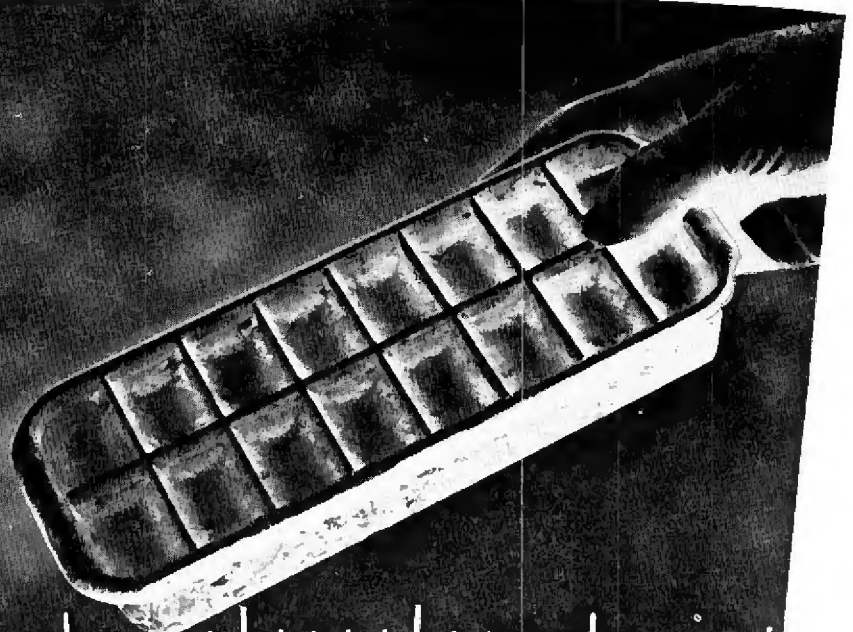

and **DRINKS** kept cold

## The OBJECT

### Boston and New York Utilities Pass Service Calls to Dealers. Others Assume Leadership in Campaigns to Stimulate Replacement Buying, Boost Second-Set Sales

In May, The Edison Electric Illuminating Company of Boston offered to prepare and mail to its customers 1,000 letters per dealer operating in districts on its lines, recommending a \$1.50 checkup (Plan modeled closely after that of RCA). The Utility was to prepare the letters, pay the postage. All dealers had to supply was their own letterheads and envelopes. In some instances, where small dealers did not have letterheads, the Utility printed these for them. In all cases replies went directly to the dealers themselves.

An appropriation of \$1,400 was made to cover the Utility's share of the expense. This included window signs for cooperating dealers, tying in with the mailing. The plan was presented to dealers by Julius Daniels and their approval obtained. 150,000 letters have since been mailed for 90 retailers and the resulting business

obtained by these retailers, both in service and new set sales, has been sufficiently impressive to induce the Utility to consider instructing all of its home service representatives to take hold of the campaign too. Expansion in this direction is being considered as we put this issue "to bed."

Load-building is the sole object. The Utility estimates that there are 300,000 home radio sets in the territory it serves and that 120,000 of these are in only fair operating condition. Based on a three-cent rate, if the use of all sets could be increased one hour per day the estimated additional power revenue would exceed \$100,000 per year.

Still another company effort to help dealers sell through service comes to our attention.

The New York Edison Company, beginning in May, included in circulars inclosed with all electricity bills

a "plug" for a \$1.50 checkup (this plan, too, is modeled after RCA's). Calls received from this promotion are distributed among local dealers and the activity, directed by D. S. Melvin, brought in an average of 325 per month from June through September.

Response today is rapidly nearing the 1,000-per-month mark and dealers receiving the inquiries report that the average grosses \$4.25 in service time and materials and that the plan simultaneously presents an excellent opportunity to broach the subject of a new receiver to many people who would not ordinarily be contacted.

And there is still more evidence of radio promotion revival by electric companies. Several others have indicated interest in proposed plans of cooperation with dealers for the sake of load and, as we go to press, Public Service of New Jersey is rumored



to be contemplating action on a service checkup plan.

Such efforts are definitely constructive.

### **Trouble, Also In The News**

Power company promotional methods can also go haywire, incurring the antagonism of many of the very dealers through whose sales effort the Utility hopes to increase its load. On our desk as we write is the following news item released by an electric company operating in one of the country's major merchandising centers, an announcement that has stirred up a veritable volcano of dealer and jobber comment.

We reprint it, omitting only identification:

"The \_\_\_\_\_ Company has announced the most intensive electrical appliance promotion campaign ever attempted in the territory served by that company. The activity will be known as the 'Electric Necessity Bargain Package Campaign.' It is an effort to place in the homes of the large group of minimum users of electricity those appliances considered to be essential to the comforts of modern electrical living. Through the cooperation of manufacturers, the equipment to be promoted will be offered at approximately half the regular list prices. (Italics are ours. Ed.)

"The campaign will be backed up by extensive newspaper and direct mail advertising and by the distribution of display material to the 225 approved electrical dealers in \_\_\_\_\_ and \_\_\_\_\_, who will participate with the company in this activity.

"There are some \_\_\_\_\_ customers on the lines of the company who are in the minimum user group. The campaign will begin on December 1 and will continue as long as is necessary to enable the electrical interests cooperating in this activity to canvass all those not using the equipment to be featured.

"The appliances to be promoted in this 'electrical necessity' campaign are irons, toasters, the I.E.S. floor lamps and small radio sets. Two bargain groups have been formed, to be known as Electric Necessity Package No. 1 and Electric Necessity Package No. 2. Package No. 1 will contain a \_\_\_\_\_ toaster, a \_\_\_\_\_ iron and a \_\_\_\_\_ I.E.S. floor lamp with 100-watt bulb. It will be priced at \$8.82. Package No. 2 will contain the same appliances and an \_\_\_\_\_ ac.-d.c. table model radio in addition. It will be priced at \$17.64.

"Customers of The \_\_\_\_\_ Company will be able to purchase these bargain packages on a partial payment basis without any financing charge. Package No. 1 may be paid for at the rate of 75c a month, for twelve months, or less than 2½ cents a day; package No. 2 may be paid for at the rate of \$1.50 a month, for twelve months, or less than 5 cents a day. Those who are not customers of the company will be required to pay cash. The bargain packages will be on display in all the showrooms of the company and the stores of the cooperating electrical dealers and will be delivered either by the dealers or by the Company.

"The \_\_\_\_\_ Company has planned

this activity on a basis of no profit to itself."

"... and blessed little profit for the cooperating retailer," said 63 dealers meeting to discuss the plan shortly after its announcement, some of them speaking as representatives of neighborhood associations and some even approved by the Utility for inclusion in the cooperative campaign.

### **Opinion Apparently Divided**

Dealers attending a Utility-sponsored dinner at which the package plan was announced are said to have greeted the program with great enthusiasm, which would indicate a division of dealer opinion. A *Radio Retailing* reporter, assigned to cover the independent meeting mentioned in the paragraph above, held November 23, states this group's objections to the package plan in question are as follows:

1. Package number 1, involving the sale of \$9 worth of merchandise, returns the dealer only \$1.30 gross, or roughly 14 per cent. Package number 2, involving the sale of \$18 worth of merchandise, returns the dealer only \$1.82 gross, or roughly 10 per cent. This precludes the possibility of a satisfactory net profit.

2. The plan, as stated in the Utility's own announcement, represents a virtual 50 per cent price cut and so places the power company . . . which should build load while at the same time advancing dealer interests . . . in the ranks of leader merchandisers who are already too numerous for the average dealer's good.

3. The campaign breaks just before Christmas, at a time when the dealer's ability to get volume at good prices is at its peak. Price cutting, to which the trade needs little introduction, is especially undesirable at this time, it is felt.

4. There appears to be some question in the minds of many in this group as to the qualifications necessary for Utility "approval". If approval means building load for the power company by forfeiting profit on merchandise sales not a few will forego filing applications.

Breathing fire and brimstone, as many of this group are, our reporter informs us that a majority, realizing the Utility's potential power for good, is apparently still eager to have it promote radio, but without preempting the radio dealer's rights. A hastily formed organization is striving to direct the Utility's efforts into more mutually beneficial channels by diplomacy and conference rather than by drastic action.

Some connection is probable between the meeting of the dealer group reported above and a letter mailed November 27 to the Utility by the managing director of an electrical wholesaler's association operating in

the same area. While there is no means by which we can readily determine just how many "heads" are actually represented in the business groups referred to therein it is obvious that sufficient opposition has been generated to militate against effective cooperation between the Utility and the trade at large, so necessary if both are to profit.

We reprint the entire letter, once again omitting only identification. Note that here, too, is evidence of a desire to go along with the Utility in its radio and appliance promotional plans and firmness only with respect to the proposed method:

"On behalf of the majority of the appliance manufacturers, the electrical wholesalers, department stores, radio and electrical appliance dealers, hardware and jewelry retailers of \_\_\_\_\_, who have all met during the past week to discuss your announced merchandising plan, I have been instructed to request that in the interest of the above you do not proceed with your plan which is to take effect December 1st, but that you permit me to call together a committee representing each of the above branches of the industry, for the purpose of working out some plan acceptable to them, which will at the same time accomplish your objective which is, I understand, to place in the hands of your consumer in the lower brackets, high-grade appliances at prices so attractive that they cannot do without them.

"We are fully in accord with your aims. Our objection is your method of accomplishing them. We believe we can, with your support, accomplish the result you desire, and at the same time, the manufacturers, wholesalers and dealers in the area can secure the profit to which they are entitled on the sale of this merchandise.

"I stand ready to call a meeting as above outlined, of the heads of the various associations affected, as well as representatives of each group, at a moment's notice, upon receipt of advice from you.

"I might further state that the groups involved stand solidly behind a satisfactory adjustment of our problems, or the taking of any legal action necessary to bring such activities to a stop for all time."

Much to our regret we cannot at this writing record a satisfactory conclusion. For final negotiations . . . if such can be arranged . . . will not be in progress until this issue is rolling off the presses.

We sincerely hope the single case of friction in an otherwise well-oiled trend will all "come out in the wash," with the Utility getting its additional load and the trade getting its merchandising profit. For in this new inclination of power companies to promote radio we plainly see rallying of an additional and extremely potent force for advancement of the radio business.

The radio business can use it.



# FIGURES

## LINES PER DEALER

Questioning a cross-section of dealers throughout the country, *Radio Retailing* finds that at the present time 25.4 per cent carry only one line of sets, 24.8 per cent carry five lines, 19.05 per cent carry two lines, 15.87 per cent carry three lines and 15.08 per cent carry four lines.

Not all lines carried are pushed, however, for 79.82 per cent feature one line, 12.84 per cent feature two lines, 4.59 per cent feature three lines and 2.75 per cent feature five lines.

One line of tubes is stocked by 40.83 per cent of the dealers reporting, two lines by 39.17 per cent and three by 20 per cent.

## HOLIDAY SALES GUESSTIMATE

From district and cooperative offices of the Department of Commerce, through Secretary Roper, come the following predictions of probable Christmas business for big-city retailers in all lines.

*Atlanta:* 25 to 33 per cent above last year. *Birmingham:* 25 to 50 per cent above 1935 and equal to 1929. *Boston:* 15 per cent over last year but 18 per cent below 1929. *Buffalo:* 25 per cent up, equal to 1929. *Charleston:* 40 per cent better than last year and 5 to 10 per cent over the boom peak. *Chicago:* Up 12 per cent to '29 level. *Cincinnati:* 12 to 15 per cent rise, but slightly under 1929. *Cleveland:* 21 per cent better than 1935. *Dallas:* 25 per cent rise expected. *Denver:* 12 per cent increase

anticipated. *Detroit:* 15 per cent rise. *Houston:* 20 to 30 per cent better than 1935. *Indianapolis:* 20 to 25 per cent increase, probably exceedingly 1929 slightly. *Jacksonville:* 15 per cent over 1935, 5 per cent over 1929. *Kansas City:* 15 per cent rise. *Los Angeles:* 15 per cent up and within 11 per cent of '29. *Louisville:* 20 to 30 per cent increase predicted. *Memphis:* 20 per cent up, probably 5 per cent over 1929. *Milwaukee:* 18 per cent better volume anticipated. *Minneapolis:* 10 to 20 per cent stepup. *New York:* Budgets anticipate 15 per cent greater demand. *Norfolk:* 20 to 25 per cent above last year. *Philadelphia:* 37 per cent gain and only 8 per cent under 1929. *Pittsburgh:* 20 per cent better. *Rochester:* 15 per cent pickup. *San Francisco:* 15 per cent rise unless maritime strike spreads. *Savannah:* 30 per cent above 1935 and probably slightly over '29. *Seattle:* 15 to 20 per cent rise. *St. Louis:* 18 per cent gain for year, 6 per cent below 1929. *Washington:* 15 per cent up and only slightly short of peak. *Wilmington:* 20 per cent rise, about 10 per cent below 1929.

## 718,000 AUTO RADIOS WANTED

71.8 per cent of one million users of all makes of automobiles, asked in a

## RADIO'S ADVERTISING DOLLAR

By Comparison with Other Industries



survey by the customer research division of General Motors what they would demand in their next car, said: "Radio". To men who must anticipate coming antenna needs it will be interesting to know, further, that 85.2 per cent expressed preference for solid steel tops and 90.4 per cent wanted streamlines.

## IT'S THE MFR. WHO PAYS

U. S. Internal Revenue Bureau collections of the five per cent tax on radio and phonograph apparatus (excluding auto-radio) during the month of October, 1936, were \$869,136, an increase of 35 per cent over the same month last year.

Excise taxes on mechanical refrigerators were \$572,235, compared with \$258,797 in October, 1935.

For the ten month's period ending October, 1936, the total radio and phonograph taxes collected were \$4,968,909, an increase of 58.5 per cent over the same period of 1935.

## EXCERPTS ON EXPORT

American radio equipment exports for the month of September, tabulated by Alexander V. Dye, director of the Bureau of Foreign and Domestic Commerce, were as follows (Hawaii, Puerto Rico and Virgin Islands excluded):

60,949 sets valued at \$1,549,838, 809,933 receiving tubes valued at \$336,867, \$547,604 worth of receiver parts, 40,886 speakers valued at \$79,003.

Other receiver accessories (Alaska, Hawaii, Puerto Rico and Virgin Islands excluded): \$48,036.

## FEATURES THAT SELL

(Ranked In Order of Importance By Dealers)

JUNE*	NOVEMBER†
1 DIAL APPEARANCE	1 DIAL APPEARANCE
2 SHORTWAVE COVERAGE	2 CABINET APPEARANCE
3 IMPROVED TONE	3 IMPROVED TONE
4 NEW TUBES	4 SHORTWAVE RECEPTION
5 INCREASED SELECTIVITY	5 SELECTIVITY
6 BETTER CABINETS	6 SPEAKERS AND Baffles
7 TUNING INDICATORS	7 AUTOMATIC SHARP TUNING
8 CIRCUIT REFINEMENTS	8 TUBE IMPROVEMENTS
9 EFFICIENT SPEAKERS	9 CIRCUIT IMPROVEMENTS
10 ASSEMBLY AND PARTS	10 ASSEMBLY AND PARTS

\* Survey of 300 dealers (Page 15, June Issue)

† New Survey of 129 Dealers



# SERVICE IS THE SMALL

**T**HE small retailer today, as thirty years ago, is the backbone of the retail business despite all that department stores, chain stores, mail-order houses and other mass distributors have done in recent years to build sales volume for their particular type of system.

That observation might be made by any student of retail trends without stirring the emotion of a single radio merchant because it represents no more than a statement of facts.

However, when it is voiced by the president of one of the world's largest manufacturers of radio sets it takes on much and precious significance. For it must follow that, while thus recognizing that importance, he cannot help but direct the sales policies of his company into channels that will assure proper and ample protection of the interests and position of those small dealers.

This deduction is just 100% correct when applied to E. T. Cunningham, the president of the R.C.A. Manufacturing Company, Inc. of Camden, N. J.

When Mr. Cunningham was asked to discuss what he considered at the moment as one of the major problems of the radio industry, he did not grope around for an answer, he did not talk about finance, or new models, or the tube situation or any one of the hundred and one other problems that the head of such a large manufacturing concern has to wrestle with.

He by-passed all the intermediate steps of production and distribution and went straight to the actual battle front of the radio business, namely the radio dealer, in whose shop Mr. and Mrs. Consumer meet the industry's products.

Said Mr. Cunningham: "I think the thing that is needed most, is more intimate contact with small unit retailers and more and better cooperation in their behalf."

And just to show that this interest in the radio retailer was not just a bit of stage play put on for the benefit of a special audience, Mr. Cunningham promptly proceeded to prove that he knows exactly what he is talking about when he voices the need for more intimate contact between a manufacturer of radio sets and the retailer.

He continued, "Particularly in the past twenty years merchandising in

**Top executives of big corporations often are reluctant about breaking into print with any personal views on problems of their industry and, broadly speaking, E. T. Cunningham is no exception to that rule.**

However, when it was pointed out to Mr. Cunningham that *Radio Retailing* was offering him an opportunity to send a personal, yet informal message to all worthwhile retailers and servicers of radio sets and untold thousands of salesmen, he readily consented.

After reading this interview many dealers will wonder how a man in Cunningham's position should know so very intimately and accurately the most pressing problems of the radio retailer.

Therefore it seems only fair to let them in on a fact that is not widely known—namely—that 25 years ago Mr. Cunningham himself was just one of those independent retailers.

In other words he knows the retailers' problems from personal experience.

the large urban centers has undergone a rapid transformation. The large department stores and chains developed an aggressive form of promotional merchandising. Their volume of business permits them to use large space continuously in the metropolitan newspapers and their organized man power specializes in mass merchandising and continuous and active promotion and stimulation of consumer demand. Special prices and special offers play a very large part in this activity."

Even a college professor of marketing would have to admit that in those words Mr. Cunningham summed up effectively the type of high-power competition that the independent retailer has had to contend with in the last two or three decades.

### *Don't Try to Copy*

However, Mr. Cunningham did an even better job of summarizing the independent retailer's position in that competitive field when he said, "The small independent retailer cannot operate on the same basis as those large retailers and his survival and his profits *depend on his individual development* of a plan of merchandising service in his area, that obtains for him his share of the business in competition with the large store advertisers."

And—how could anyone summar-

ize the handicaps of the small retailer more completely than did Mr. Cunningham in his next remark: "The small independent retailer must recognize that he must have an entirely different conception of his operations in rendering his service to actual and potential customers."

"He cannot buy in the same large quantities with the same vast assortment (as his big-store competitors) and for his buying he must largely depend on the assistance and guidance of a few distributors who serve him. He very seldom can use the metropolitan newspapers for advertising as the rate and coverage are both out of his reach. He cannot feature price specials and promotions as frequently or with as great variety as the large stores."

Now, anyone who has ever had the opportunity to talk with Mr. Cunningham knows instinctively that he would rarely launch into an important subject without having some very definite thoughts and suggestions to contribute.

Therefore it was not difficult for the interviewer to extract from Mr. Cunningham some very concrete and entirely practical suggestions as to how the independent dealer should meet the competition that he finds in his neighborhood.

Said Mr. Cunningham: "The small unit dealer in deciding on his policies,



# DEALER'S STRONGHOLD

On this home-ground department stores, chain stores and mail-order houses have no advantage

says

## E. T. Cunningham

President, RCA Manufacturing Co., Inc.,  
A Radio Corporation of America Subsidiary

This is the third in a series of interviews with important industry executives by O. FRED. ROST



it seems to me, must first consider that he is rendering a *neighborhood service* and he should then develop selling and advertising methods within his means, to bring his store and his service accurately, appealingly and continuously to the people in his neighborhood.

"It is most important that the outside of his store and show windows and the inside of his store present a clean, attractive appearance that will give confidence to his local neighborhood in doing business with him.

"Continuous display of well-known brands is the best means of impressing his store on the minds of his community as being operated by a reliable merchant. He should be particularly careful to see that the appearance of his sales people and other employees who contact customers is fitting and proper.

"In short, he must identify himself with his local community as a reliable, courteous source of merchandise service and he must put his relations with his customers as far as possible on a personal basis," and then Mr. Cunningham finished off that part of his suggestions with a 15-word broadside that represents the very crux of the independent dealers' strength. Here it is: "The large stores offer an impersonal service; the small retailer can offer a personal service."

Those 15 words should be remem-

bered by every independent dealer as long as he is in business because they express what is his greatest strength, the bulwark of his position and the one thing that he can claim always and forever as an advantage over the most efficient big-store or chain competitor.

### *Repairs A Weapon*

Then Mr. Cunningham brought up a subject that is particularly vital to the radio industry as a whole and one in which again the independent retailer can claim and preserve an inestimable and highly valuable advantage, namely, the service situation. Here again Mr. Cunningham displayed not only an intimate knowledge of the problem involved but he had some very constructive suggestions that dealers may well follow.

He said, "Some of the large retailers are actively developing reliable efficient service departments. In my experience too many of the small retailers look on service as something that is expensive to them, instead of looking on *service as one of the most valuable departments that a neighborhood merchant can develop.*"

"Service can be placed on a business, money-making basis. It offers the finest opportunity for the small retailer to have continuous contact with the homes in his community and out of those contacts he can build

sales for many merchandise items."

"The American home is becoming steadily more electrified and more mechanized. It cannot get along with modern equipment without service. Service must be rendered by men trained in that field. The servicing of a radio set, the proper installation of an aerial, the servicing of a refrigerator, vacuum cleaner, etc.—all are sources of constant revenue, that the local neighborhood merchant should develop."

"In many cases the alert dealer is realizing this. However, it is necessary that in organizing the service department the dealer should obtain most competent help, *should charge the full value of the service rendered and should stand behind the work done.*"

Then, in conclusion, Mr. Cunningham delivered himself of an observation that every small independent retailer might well memorize, paste on his desk, paste on his cash register and into his hat, because it expresses what constitutes the formula to success for the independent merchant in holding his own in competition with the big stores, mail order houses and chains.

It is this:

"Personalized, courteous service, plus prompt efficient servicing are the two basic fundamentals for a neighborhood dealers' success in the radio business."

# DISPLAY ..... MANAGEMENT .....

## Records And Combinations As Leaders

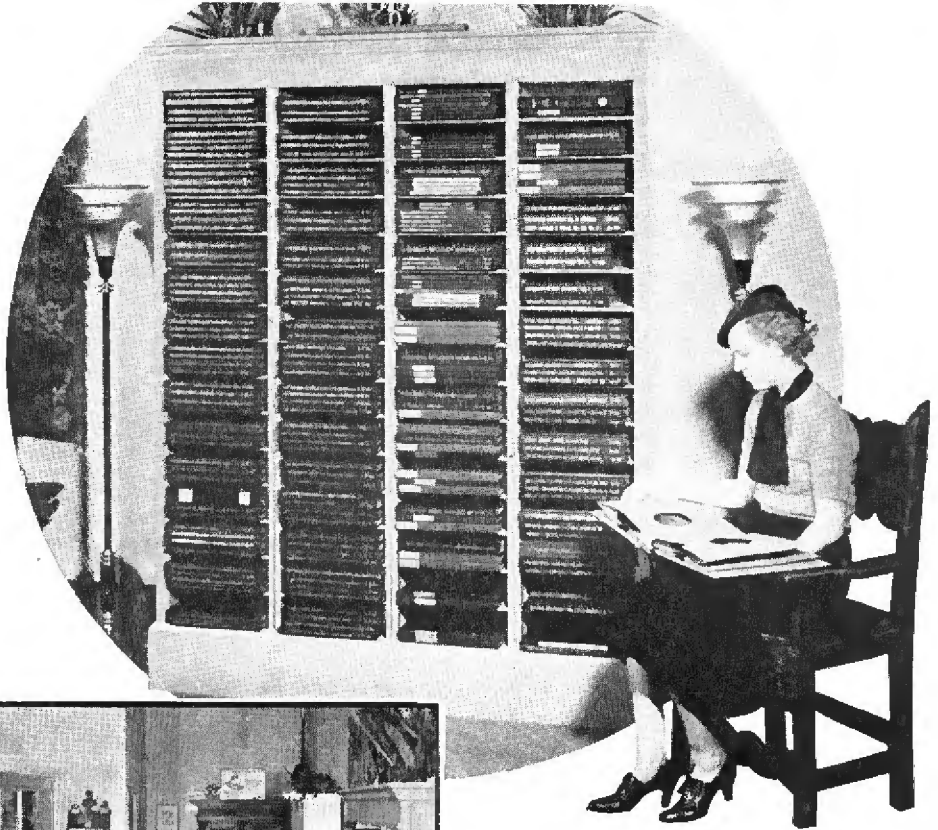

**HIGHBROW AND LOWBROW**—In records as in sets on which to play them this shop sells down from quality merchandise where necessary rather than up from popular-priced items

**SO OLD IT'S NEW**—By specializing in merchandise still played down by the average radio shop partners Helen Gunnis and Ralph Grassler appropriate for themselves first rank position in a field involving comparatively little competition

MILWAUKEE—When radio first tickled the consumer palate many music stores stocked sets as a line incidental and secondary to phonographs. Then the tremendous strides made by the new art eclipsed record reproducers and the demand for discs, never completely obliterated and today climbing rapidly, was completely ignored.

Reversing usual dealer thinking and so lifting itself out of the welter of ordinary radio stores, the Helen Gunnis Record Shop, recently opened here, once again headlines records. Discs, combinations on which to play them, and individualized, hand-carved cabinets that go hand in hand with quality musical instrument business are the

concern's leaders. Straight radios are stocked for the average consumer but play second fiddle to combinations in all promotion.

By specializing in merchandise still played down by the average radio shop, partners Helen Gunnis and Ralph Grassler appropriate for themselves first rank position in a field involving comparatively little competition. By featuring instruments and accessories ordinarily relegated to a dark corner Gunnis and Grassler attack one of the industry's most difficult problems from a new angle, automatically attracting quality trade with money to buy higher unit price equipment and then "selling down" if necessary.

Obviously, the shop's approach is not one adaptable by all dealers in all localities. But its experience is proving that there is room for one such specialist in Milwaukee. Which indicates that there is room for others elsewhere. The store's appearance is new, yet simultaneously old. Like the music stores of the early days a home atmosphere is carried out in the central salesroom. Fine tapestries adorn the walls; several genuine Japanese oil paintings and three fine bronzes are seen. The furniture is all period design. The store is 49 by 22 feet overall, carpeted throughout and indirectly lighted. Audition rooms are 6 by 8 feet, built of celotex and supplied with Mexican chairs and end



# ADVERTISING . . . . SELLING . . . .

tables. Instead of old-fashioned, conventional outlets along the walls, strip moulding provides a.c. outlets every 6 inches.

The shop carries the largest retail stock of records in the Northwest. Popular numbers are stocked heavily but foreign recordings and classical libraries are also sold in considerable number.

The sale of individualized, hand-carved cabinets, probably because these sell readily to just the type of customer interested in classical recordings, is increasing rapidly and accounts for more and more of the shop's revenue each month. Straight radio sales, while perhaps not phenomenal from the average dealer's viewpoint with respect to unit volume, bring in a nice dollar profit. For the Helen Gunnis Record Shop works from the top strata of buyers *down* to the average consumer, rather than from the lower strata *up*.

Records, combinations and hand-carved cabinets are the sales spearhead of this radio retailer.



ALASKA-BOUND—"M. S. Electron", equipped by Seattle Radio Supply to sell tubes and render radio service, gets under way for the far-north

## Service From The Sea

SEATTLE—The "M. S. Electron," now wintering in the harbor at Juneau, Alaska, is (so far as we know) the only sea-going radio tube and service shop in existence. Owned by skipper G. E. Goudie and operated in the interests of the Seattle Radio Supply Company, distributor, the ship brings to dealers in or near the coastwise towns of the inaccessible and far-northern peninsula a complete Tung-Sol

stock and expert repair facilities for sets that puzzle local talent. In addition, its staff renders an invaluable service to other boats plying Alaskan waters by repairing commercial transmitters, charging batteries and even re-winding generators and motors.

The crew is particularly well fitted for its job. G. E. Goudie has been connected with the radio industry since 1920, is a graduate of electrical and

radio engineering from the University of Washington, built KDZZ, one of the Pacific Northwest's first broadcast stations and has been with Keystone Research, Radio Engineering and Manufacturing Company and the North West Laboratories. He holds amateur license W7DH.

His brother, Jack Goudie, is a well-known marine engineer and a licensed commercial radio operator. Fred

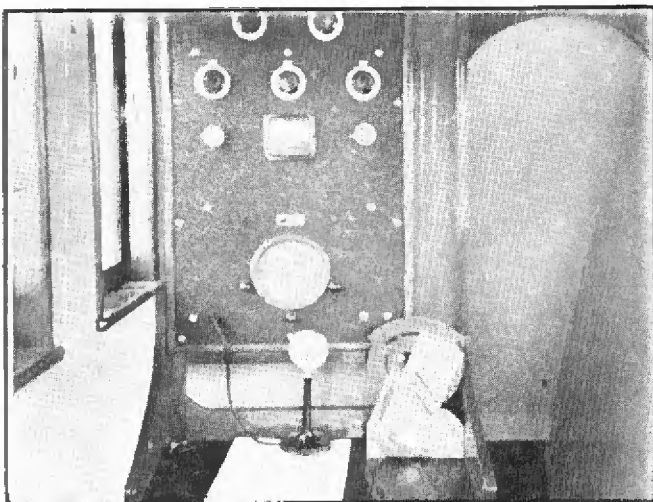

WOOD—Here's the boat's commercial 'phone transmitter. The crew builds such rigs to order, fixes 'em and relays messages ashore for other mariners



DISPLAYS AND BENCH—When the ship drops anchor dealers can come aboard, be impressed by the tube displays and see repair work in progress on the bench

Greenalgh, W7DWH, is a commercial receiver specialist. And W. O. Witte, also a licensed commercial radio operator, is an electrician.

Equipment includes 110 volts a.c. or d.c. from 8,000 lbs. of Globe-Union batteries and a generator, complete electric and acetylene welding apparatus and a complete radio test bench.

M. B. James of Seattle Radio Supply (pinch-hitting as a reporter because the "Electron's" crew is at present operating in the Alaskan interior, where they will remain until the ship is again commissioned in the spring) advises that the company's Alaskan business runs into many thousands of dollars a month and that use of the unique sea-going shop is rapidly increasing volume. The ability and engineering experience possessed by the various men comprising the crew has enabled them to secure many government contracts and radio service business which has never been touched before.

Tung-Sol tubes, according to James, are consigned to the ship from the Seattle headquarters, re-consigned by the ship to dealers of the northern peninsula for sale to the retail trade. The only difficulty reported is the poor mail service in the winter. This holds up consignment reports which are vitally necessary for sales planning and stock re-filling.

He hopes to solve this one problem.

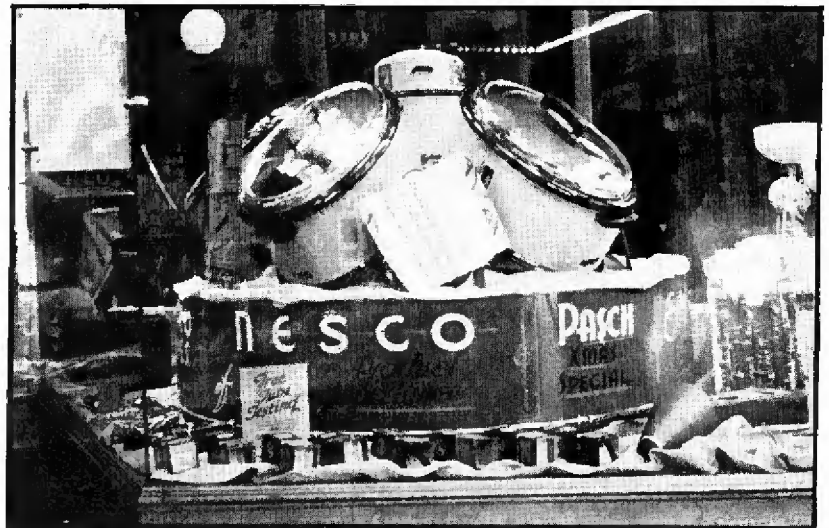

**APPLIANCES GO 'ROUND**—This window turntable, representing a \$65 investment, paid for itself in ten days, according to Morris Pasch of Milwaukee. It is 4-ft. in diameter and will handle three console radios

## Telephone Technique

MILWAUKEE—Use of the telephone as a speedy means of getting in touch with prospects is recommended highly by the Pasch Radio Stores. This organization makes 50 calls per day and of this amount 5 per cent, at last count, buy merchandise.

A close check on sources of new business recently revealed that 47 per cent was obtained from old customers who had patronized the store in the last 14 years. So the first step in the Pasch telephone campaign is to go over its old customer list. Second, the firm obtains a voting list and checks this against the city directory and telephone book.

The city directory gives the occupation of every person listed therein. If a man is listed in the directory as having a good job but has no telephone his name is jotted down for a future personal call. Many people who have money to buy do not have 'phones, according to Morris Pasch, because they do not wish to be bothered with a lot of calls. This percentage runs about 10 per cent, he believes, the remaining 90 per cent having little objection to telephoned sales solicitations if these are diplomatically handled.

Seasonal interests are plugged in all 'phone solicitations. Say, for example, that it is near the fall buying season. People who had been contacted before and said they might be interested in the fall are concentrated upon. If personal calls were made on everyone enjoying this status, according to Pasch, it would take six months or more to cover the ground. Furthermore, by the time the list was worked over the buying status of many would have changed.

Speed is the essence of modern selling, he contends, and good coverage of prospects at an economical rate can only be accomplished by telephone.



**CIRCULAR RADIO DISPLAY**—Useful to departmentalized stores such as that of Markowitz & Resnick, Miami, is this circular counter idea. It presents table models to advantage, keeps radio away from other merchandise and provides a "protected" area for consoles



# DIAL



## A NEW HIGH SALES FIGURE WITH THE NEW KADETTE *Tele-matic*

### AC MODEL 35

Kadette, always a step ahead of the radio parade, steps out with the only low-priced table radio having this modern type of dial tuning.

Of a long list of sales features, the most important is the new Finger-tip Tele-matic Dial Tuning. It combines the simplicity of the telephone dial with the smoothness of the vernier drive. Names of favorite stations may be inserted at proper points for instant tuning. The easily read dial is brightly illuminated at the point of tuning.

Cabinet of the Kadette Tele-matic Model 35 is modernly styled with sloping front of beautiful grain, striped walnut. Solid ends are in dark, contrasting finish—modern, bar-type grille. Size is 12½ inches wide, 12¼ inches tall and 6½ inches deep.

The Kadette Tele-matic chassis is a five-tube AC superheterodyne. Tunes complete broadcast and entire upper police ranges—540 to 1875 kilocycles (555-166 meters). Automatic volume and overload control—continuously variable tone control—high sensitivity, extremely selective. Unusually fine tone; new design dynamic speaker with greater effective cone area. Look over these features but don't overlook the high sales figure you can dial with the Kadette Tele-matic Model 35. This new Kadette will show you some real profits—wise dealers will order a good supply *right now*.

INTERNATIONAL RADIO CORPORATION  
524 Williams Street

ANN ARBOR

MICHIGAN

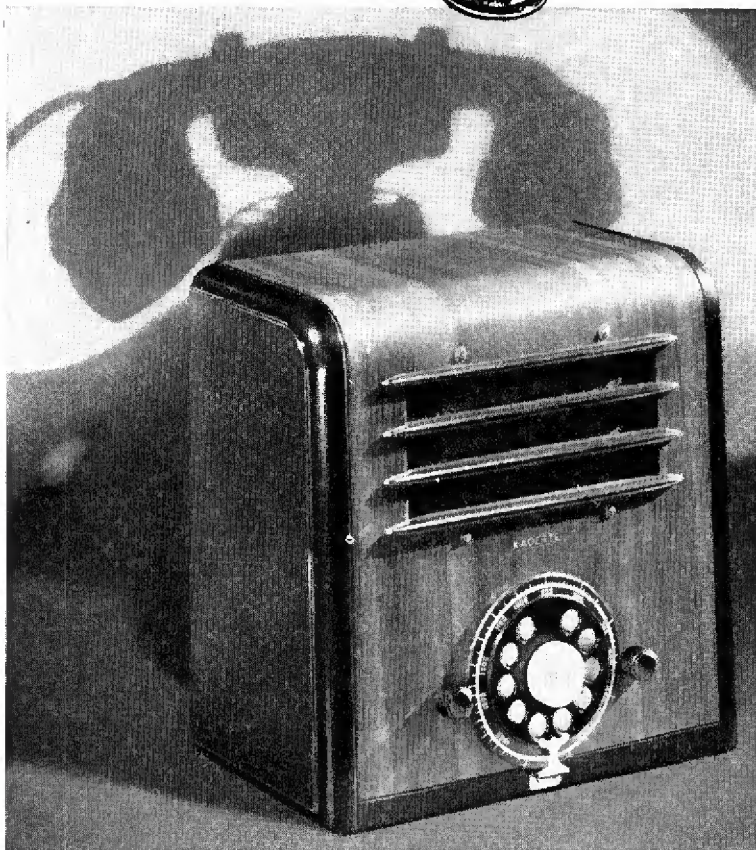

# \$24<sup>95</sup>

COMPLETE WITH TUBES

New Finger-tip Tele-matic Dial Tuning . . . new, finer tone quality . . . new cabinet of exclusive modern design . . . new high standards of performance . . . a new high in radio value.



# KADETTE

*Creators of  
Quality  
Compacts*



**EFFICIENT LAYOUT**—Note the placing of the phonograph record department and the main table model radio display at the extreme rear. Customers have to pass consoles and major appliances to buy low unit price merchandise

## Floor Sales System

DENVER—Says Herb Names, sales manager for the Wells Music Company, interviewed here:

"Floor-lead sales have increased 25 per cent and salesmen compete eagerly for 'number one' position due to the effectiveness of our new merit system of handling men.

"The majority of our sales have been coming from leads secured on the sales floor. 65 per cent to be exact. This fact tends to stimulate quite some rivalry among the salesmen. 'Who will get to work the floor?' The matter is not left to be decided by a toss-up. It has become a system.

"We have in our department six regular salesmen. Two men are used on the floor at all times, providing what we call twelve floor days in each week. The store-selling positions are divided

into six 'number one' and six 'number two' places. The 'number one' man is the one who greets every customer to enter the department unless he is busy, in which case the 'number two' man receives his chance for an initial contact.

"The first and second high men with respect to monthly sales each receive two 'number one' positions per week for the following month. The third and fourth high salesmen are allowed to work two days a week also but they must be content with one 'number one' and one 'number two' position. The balance of the floor days are assigned to the low men in sales, all in the 'number two' position.

"The incentive to work for good floor positions is obvious. Increase in our sales has been the result."

## Encourages Credit Buying

MILWAUKEE—Ray Haasch, interviewed here concerning a recent decision to encourage time-payment business even at the loss of some cash transactions, informs "Radio Retailing" that his gross profit is now averaging 35 per cent. He points out that most customers offering cash practically insist on a discount, which makes this class of business less profitable than credit transactions,

especially where an additional finance charge is made.

Haasch points out to cash customers the value of financing, which leaves funds free for other purposes. He does this even before a discount is demanded, believing that the majority of cash customers will eventually ask for one and leave the store without buying if it is not forthcoming.

## Direct-Mail Idea

ST. LOUIS—The Famous-Barr Company finds that not all people who have their old radios repaired are satisfied with them, even when a first-class job is done. The performance of newer sets is beginning to penetrate into the home and older models suffer by comparison.

Turning an annoyance into capital, the company mailed 1,000 letters on September 1 to service customers of the past two years, advising these customers that the amount of the old repair bills could be applied toward the purchase of a new set. The letters were sent only to customers whose service billing did not exceed \$5, in order to keep the allowance down. A copy of the original radio service order bill was sent along.

Twenty-seven customers responded and bought sets following the offer. Some customers called by phone to say that they had paid their service bills. The salesman answering the phone explained to such excited callers that the letter told why the bill had been sent and took advantage of the misunderstanding to suggest a new set demonstration.

All service customers now patronizing the store are advised, when they pay their bill, that the sum can be applied against a new set purchase anytime within a 30-day period.



**25 TUBES, SO WHAT**—RCA Victor dealers in the Cedar Rapids territory have found an excellent answer for those prospects who judge the value of a radio solely by the number of tubes. The "prop" basket illustrated is trotted out



☆ ☆ ☆ *Orders Totaling* ☆ ☆ ☆

**\$15,000,000**

***PLACED BY DISTRIBUTORS  
AT SPECIAL PREVIEW OF  
1937 NORGE APPLIANCES***

**Amazing New Line  
Scores Smashing Success**

The 1937 Norge Home Appliances shown in a special preview to Norge distributors caused the greatest sensation in the history of the company. Backing their tremendous enthusiasm with \$15,000,000 worth of signed orders, the distributors attending the meeting predicted that Norge would cause the greatest buying wave in home appliances that the industry has ever seen. Again Norge leads with products that sell on sight!

**A WORD TO WISE DEALERS: WAIT!**

***AGAIN NORGE LEADS!***

***Enthusiastic Acceptance  
Sets New Record***

In addition to presenting products with the greatest natural sales appeal ever found in any complete line, Norge announced the biggest sales promotion and advertising campaign in its history! Alert dealers will fall into line in the Norge Profit Parade immediately. Liberal finance plans make it *EASY* to be a Norge dealer, too.

**DEALERS: MAIL  
COUPON NOW!**

**NORGE DIVISION** Borg-Warner Corporation, Detroit, Mich.

*Please send me full information on the 1937 Norge line and details of the Norge dealership proposition:*

NAME \_\_\_\_\_

ADDRESS \_\_\_\_\_

CITY \_\_\_\_\_ STATE \_\_\_\_\_

*See the Sensational  
**NORGE**  
HOME APPLIANCES  
Before you Sign Up For 1937*

Rollator Refrigeration (Domestic and Commercial) • Gas and Electric Ranges • Washers and Ironers • Water-Oil Burners • Fine-Air Furnaces • Air Conditioning • Circulator Room Heaters

# S O U N D . . . . .

## Then Businessmen Don't Tire

- **INTER-OFFICE COMMUNICATION SYSTEMS** save footsteps, speed up routine
- New "package merchandise" is compact, often easier than radio to install



**CONFERENCE, REMOTE-CONTROL**—Remler unit, neatly encased in Bakelite, flatters the busy executive's desk



**FAST AND ACCURATE**—Here's one end of the Turner speech control system in operation



**YOU'VE SEEN THIS ONE**—John Barrymore, in the flicker "Counselor At Law", uses a Telematic (Dictograph Products)

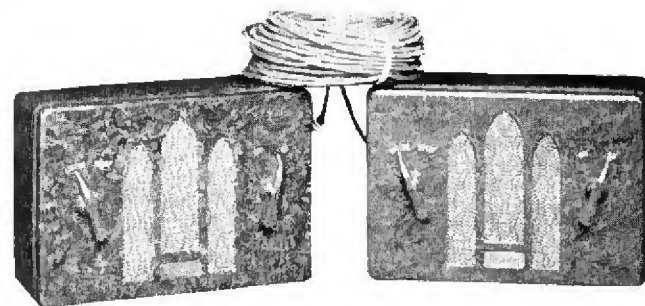

**COMPACT, SIMPLE**—A complete setup made by Simplex shows absence of complicated wiring

**FREES TELEPHONE EAR**—Talk to a customer and check with other departments over a Belfone (Bell Sound)



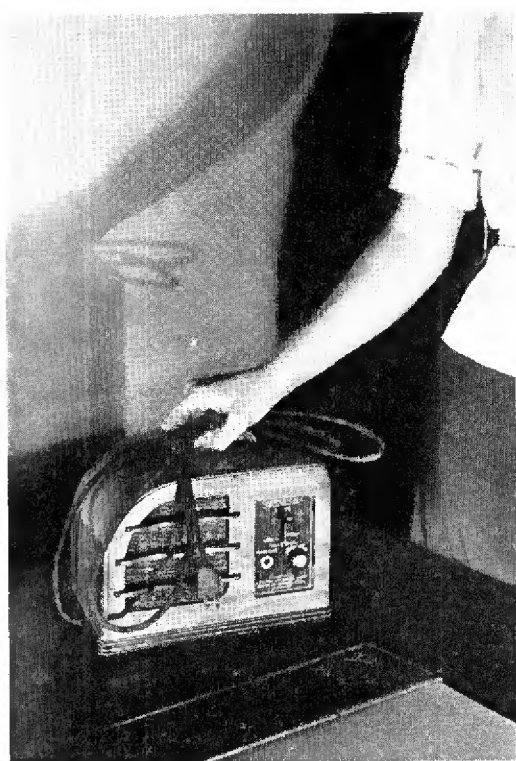

**READILY PORTABLE**—*Carrier-Call* can be quickly shifted where you need it

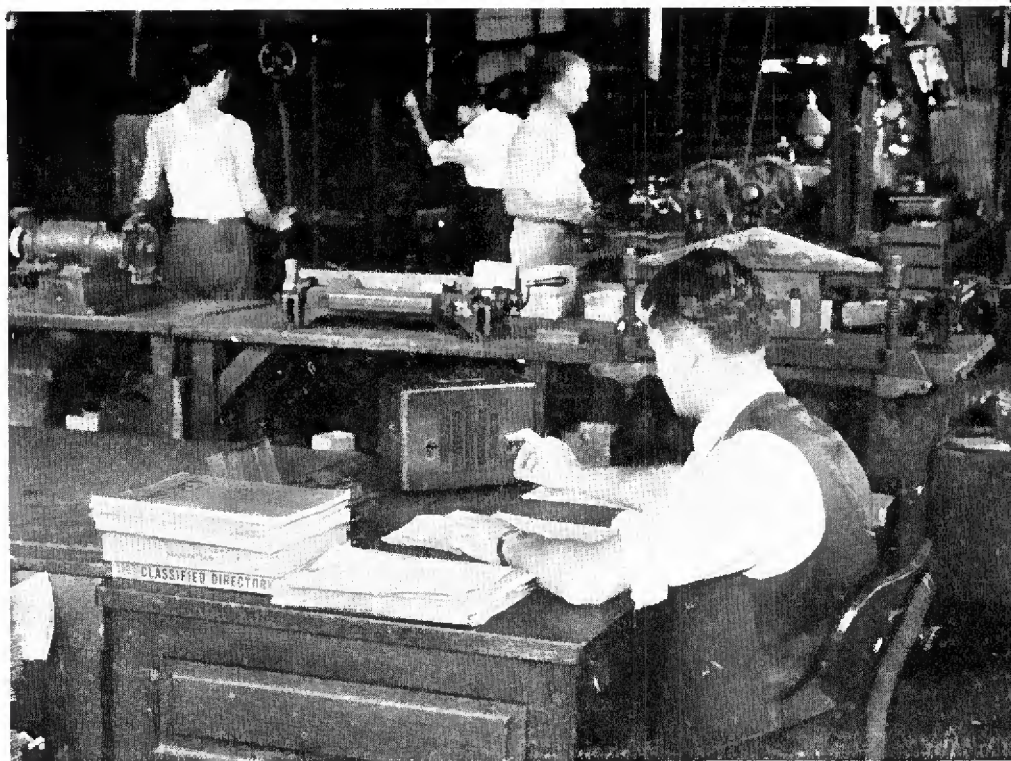

**NO BUZZERS, BELLS**—The *ElectroCall* (United Scientific Labs.) talks right up above shop noise



**NO WIRE-HOLDING**—This information clerk can reach anyone in the plant, instantly, with a unit made by *Sound Systems*

**S**OME of the equipment illustrated works just one way. Some permits the user to talk or listen but is "simplex", requiring the flick of a switch. Other units work "duplex", talk and listen simultaneously without switching.

Some systems permit individual selection of "stations". Some require inter-connection by means of wires while others use the electric light lines themselves as the transmission medium.

Practically all those shown are available in a variety of models and most manufacturers make several types. Details, obviously, cannot be given in each case. Additional information may be obtained through *Radio Retailing*, on request.

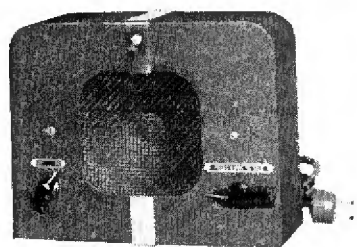

**STEEL CAN TAKE IT**—*Opera-dio* unit, completely encased in a modernistic metal cabinet

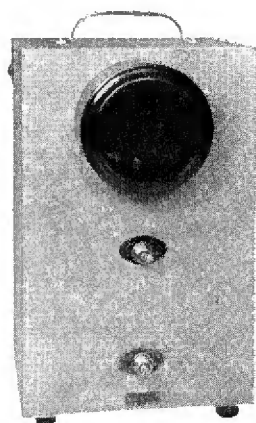

**NO MIKE TO HOLD**—Here's the socket microphone and control unit made by *Miles*

**DOCTORS, TOO**—*Teletalk* (Webster-Racine), at work in a medico's reception room





How far they travel . . .  
Freedom from static . . .  
Services available . . . Tuning tricks . . . The antenna



TRANSMITTER, IN MOTION—Policemen and amateurs in cars provide a new thrill for the listener

## EXPLAINING THE ULTRA-HIGHS

By C. A. Nuebling

**H**OW often has a customer confronted you with the statement: "My new set is fine—all except the last band. I can't get a thing—what should I hear—how should I tune it?" Possibly these questions relative to the ultra high frequencies have puzzled you also.

Contrary to some beliefs, all high frequency signals, better known as short waves, do not travel great distances. Waves shorter than 10 meters (ultra high frequencies) seldom cover more than 100 to 150 miles, and those around five meters, between 25 and 50 miles. However, this band possesses unusual capabilities for such local services as two-way police systems, television and amateur and other experimental stations in that static is not troublesome and fading non-existent. Ignition interference from automobiles is, however, present.

### *Hear Both Sides*

Two-way police installations are becoming very popular in many cities.

With such a system, both the patrol car and the dispatch station can be heard, thus the news is received as it is being made. Typical stations in the New York area can be found at Garden City, L. I., Harrison, N. Y., Newark, N. J., and Jersey City. They operate at various intervals between 30 mc. and 50 mc. on the dial.

In some sections of the country experimental television programs are being broadcast. The National Broadcasting Company, New York City, for example, has been carrying on this work for some time. The sound portion of each experimental broadcast is transmitted on 62 mc. while the picture apparatus operates on 52 mc. Of course the picture transmission is valueless without a special receiver and associated equipment, not available at present. However, the sound channel offers very interesting programs to the owner of an ultra high frequency receiver.

The 56 to 60 mc. portion of the ultra high frequencies is set aside for amateur radio stations. In most cases,

it will be difficult to hear these stations, since, because of frequency modulation, the signals jump slightly from one frequency to another and could not be followed with a selective receiver. Many amateurs are installing stabilized equipment, and in the near future it should be possible to receive these signals just as well as the commercial stations.

The tuning of these receivers is quite critical; slow, careful tuning is even more essential on the ultra high frequencies than on normal short wave bands. Once a few stations are picked up it is a simple matter to "get the hang of things."

### *Best Antenna Vertical*

Probably the most important factor in high frequency reception is the antenna system. There are various and varied types on the market. Maximum results are obtained when the antenna is approximately one half wavelength long, mounted in a *vertical* position and as high and clear of surrounding objects as possible. Customers living on high hills will generally report better ultra high frequency reception than those located in low country.

The two wire transmission-line-type is to be preferred. A simple yet highly efficient system can be devised by splitting back one end of a transmission line cable for about five feet, attaching an insulator at each end of the unraveled section and suspending it vertically. The rest of the line is carried away at right angles to the center for about 4 or 5 feet, then run down and connected to the set in the usual manner.



“AGAIN.. LEONARD WILL BE THE HOT LINE OF THE YEAR”

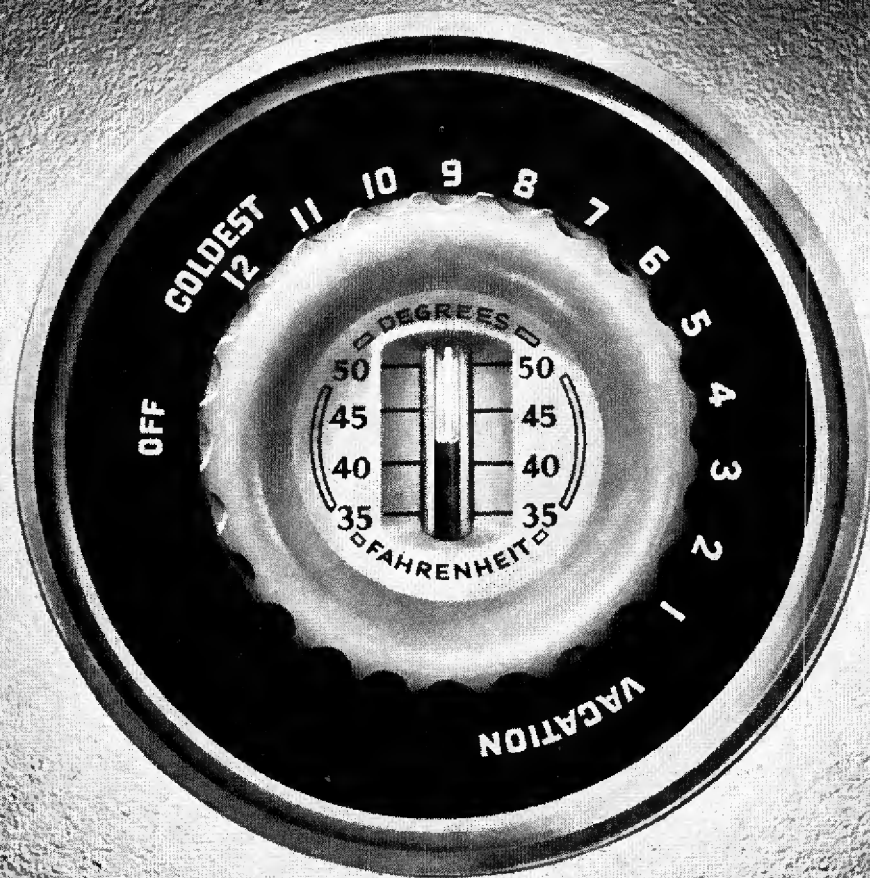

# THE LEONARD *Master Dial*

MAKES IT THE GREATEST SELF-SELLER  
THAT WAS EVER ON YOUR FLOOR !

*And Only Leonard Electric will Have it*





Each style comes packed in its own colorful, price-marked FREE DISPLAY . . . of which the above No. 990 is typical.



NO. 2122  
**39¢**  
COMPLETE

NO. 2093  
**98¢**  
COMPLETE

NO. 502  
**49¢**  
COMPLETE

NO. 2299  
**99¢**  
COMPLETE

NO. 602  
**\$1.25**  
COMPLETE

NO. 2298  
**99¢**  
COMPLETE

# LEADERSHIP in Profits Fast Turnover and QUALITY

**L**EADERSHIP in styling, materials, design—that is where these highly attractive Bond quick sellers get their big quality appeal. Supplied in popular-priced self-selling deals that turn over quickly and yield excellent profit.

### BOND FLASHLIGHTS FOR CHRISTMAS SALES

Priced to Retail Complete with Bond Super Service Mono-cells

- 39¢** No. 2122—Full chromium plated 2-cell Spreadlight. Offered special in Deal No. 390.
- 49¢** No. 502—Full chromium plated 2-cell Spotlight. Offered special in Deal No. 490.
- 98¢** No. 2093—Fibre-Bronz "Baby" Spotlight, golden bronze and black corrugated fibre. Offered special in Deal No. 198.
- 99¢** No. 2299—Fibre-Bronz in golden bronze and black corrugated fibre. Offered special in Deal No. 990.
- 99¢** No. 2298—Bronz-Lite in solid golden bronze. Offered special in Deal No. 980.

**\$1.25** Handsome Stylo Spotlight No. 602 in chromium and three different color designs. Offered special in Display Package No. 600, without batteries.

*Ask your Jobber's Salesman for full details.*  
**BOND ELECTRIC CORPORATION**  
New Haven, Conn. • Chicago, Ill. • San Francisco, Calif.





# Make Them Sing AGAIN

FAMOUS RADIO STARS WHO  
HAVE MADE RECORDS

Bing Crosby	Rudy Vallee
Kate Smith	Jessica Dragonette
Lanny Ross	Ruth Etting
Boswell Sisters	Arthur Tracy
Harry Richman	Frank Crummit

FAMOUS ORCHESTRAS

Ben Bernie	Wayne King
Guy Lombardo	Paul Whiteman
Abe Lyman	Vincent Lopez
Jacques Renard	Ray Noble
Eddie Duchin	Leo Reisman

THESE AND MANY MORE OFFER DISC  
ENCORES

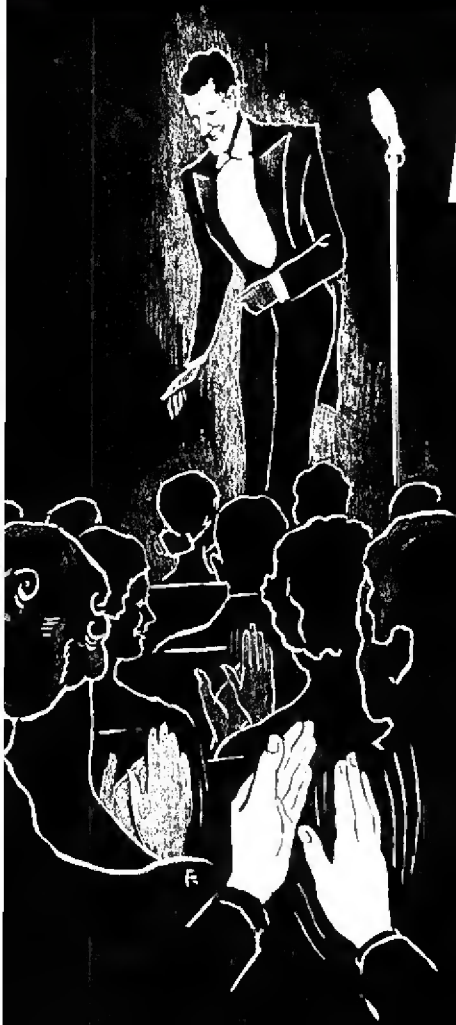

## Three Ways To Play Modern Recordings In The Modern Manner

**1** Buy a New  
**ELECTRICAL  
RECORD-PLAYER**

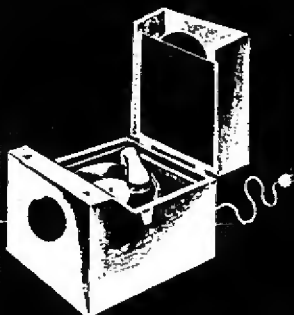

**RADIO  
RETAILING**

**2** Buy a New  
**RADIO-PHONOGRAPH  
COMBINATION**



**3** Buy a New  
**RECORD ATTACHMENT  
For Your Present Set**





# *Kelvinator cuts the cost of better living*

The keynote of the Kelvinator program for 1937 will be —“Kelvinator Cuts the Cost of Better Living”.

In a few short weeks you will learn about the program.

It will be welcomed by millions of families throughout America.

It will reach the people in your city, your town, your village.

It will herald a renaissance in the

standards of American living.

It will make possible for the man of average income such luxury as has only been dreamed of by the millionaire.

It will present an opportunity to salesmen, specialty dealers, department and furniture stores, public utilities, such as has not been known before.

You will want to know about it.

You will want to be part of it.

KELVINATOR CORPORATION

*Detroit • Michigan*

★



# THIS STORK SELLS

Another action window designed expressly for *Radio Retailing's* readers

By I. L. Cochrane

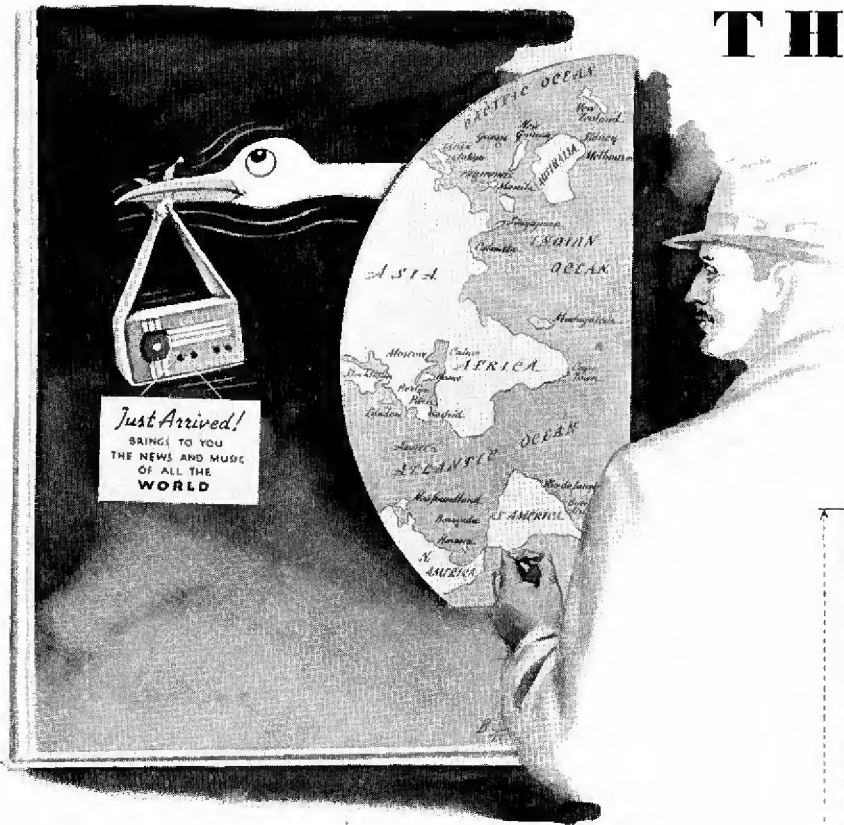

**H**ERE is an action window designed to assist *Radio Retailing's* readers in the dramatic presentation of new allwave table model radios. It also lends itself admirably to display of relatively small accessory items and minor electrical appliances.

The modernistic stork's head and neck slowly move up and down, somewhat as a genuine stork is supposed to perform while in flight. If the background is neutral, a bright color may be used to bring out the stork—preferably bright red or persian orange. The carrier cloth from the stork's bill that seems to hold the cabinet, should be in a color, or colors, strongly contrasting with the stork.

Such a gayly moving combination of color and whimsy is bound to stop almost every pedestrian passing, and arouse far greater interest than the very best still display.

The map may appear to be up-side-down at first glance, but it is merely arranged at right angles to what one is usually accustomed to see. The equator runs up and down, and not in the usual cross-wise way of maps and globes. This permits, the great broadcasting cities of the world to appear in a rectangular shape. America has little showing, but then we are selling foreign reception, and may safely let local reception be taken for granted—or left to a sentence on a sign card.

▲  
From the  
SIDEWALK

From the  
REAR ▶

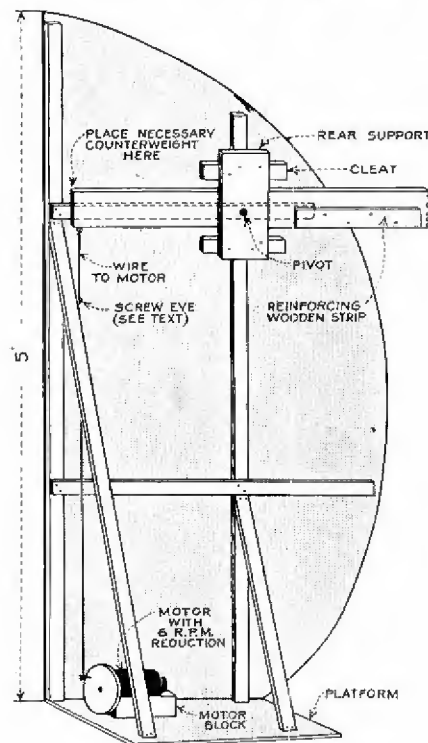

The working diagram has been drawn in detail and requires few explanations, but attention is called to the necessity of setting up a pivot that cannot wobble and creep. A smooth, fixed bolt, properly trued up, running through a smooth collar in the moving member, plus a couple of greased washers on each side will answer, if the motor delivers 1/50/h.p., or better. As the circular element on the motor shaft has an eccentric motion, it will be well to run the connecting wire through one or two eye rings, placed near the top, in order to insure a straight pull downward.

Take the chassis out of the cabinet; there is no need of this extra weight. Then cut a narrow slot in the stork's bill for the carrier cloth to pass through. Securely wire the cabinet to the stork, placing felt or other non-marring material where the wire contacts the cabinet. The cloth covers

the wire and appears to be the real support. If a thin board is used for the stork, a reinforcing board should be screwed on the rear, as suggested in the drawing. A heavy board will require no extra strengthening.

This particular motion is power one way and gravity the other. Consequently, counterweight will be required at the rear of the moving element—just enough weight so that the weight of the other end will be slightly greater, and thus allow the visible end to drop from its extra weight; the motor, of course, draws it up.

Many standard makes of back-gear reduction motors are suitable. The speed outlet should deliver about 6 rpm. Naturally, any practical reduction method will answer. It may also be well to weight the platform, especially if space limitations require a narrow one, in order to maintain the display structure in a rigid position.





# S T O R E S

Spreading rapidly is the use of trailers, modern canvassing aids. Sets, service and electrical appliances are everywhere taking to the road and dealer effort is by no means confined to rural areas

By Tom F. Blackburn

**S**TORES are growing wheels. If the mountain won't come to Mohamet then Mohamet will go to the mountain. And the modern canvassing vehicle is the trailer, powered by the dealer's family car.

This new trend in retail merchandising is everywhere becoming more apparent. Take Sander & Company, Inc., of St. Louis, for example. Quaintly the people of St. Louis call one of their highways "The Gravois." It's a typical middle class commercial street, and if you followed its diagonal stretch in 1931 you would have ultimately come to number 3552. Here the neatly trimmed windows and usual display would have revealed an average electrical and radio store. NOW the scene changes to August, 1936—



A "NATURAL" FOR ALLIED LINES—While Sander is on the ground demonstrating radios he passes up no chance to push appliances too

A burst of music under your window almost causes you to shove off a flower pot as you look out. A band below is playing "The Sidewalks of New York." Down in front a big white trailer and car has stopped. Women in kitchen aprons are entering its door. Zzzzing! goes your doorbell. "Would you like to enter a little sporting event that cannot be mentioned in a polite magazine like *Radio Retailing* because of lot-

tery laws?" asks a suave salesman.

It's the Home Appliance Caravan calling on you. Sander & Company, Inc., now wearing the colorful title of "Home Appliance Caravan."

You join the shirtsleeved, slippered, aproned throng and step inside. There you see a line of radios, a range, a washer, a refrigerator, an ironer, a cooker and a vacuum cleaner. A 110-watt light plant furnishes lights and power for the public address system.

"How do I know these things will work?" asks a visitor.

"Easy enough, brother," replies Mr. Sander. "If you will please permit me to run this extension cord into your apartment, we'll be glad to oblige with a demonstration on anything."

Elmer A. Sander is one of the first radio and electric dealers in the country to take the plunge off the spring board into an exclusive trailer system of selling. He is in a position to contrast its advantages with what he obtained from a store location.

"Some twenty-four people a day walked into our store at 3552 Gravois," he states. "Out of these we obtained from ten to eleven prospects. With the trailer we have



DISTRIBUTORS TOO — The Parker Company of Denver, distributing Sentinel farm and electric radios, reports that this trailer is one of the reasons why business is better even than 1929





# O N W H E E L S



**MISSOURI'S HIS LANDLORD**—Elmer A. Sander of St. Louis says his license plate's his rent

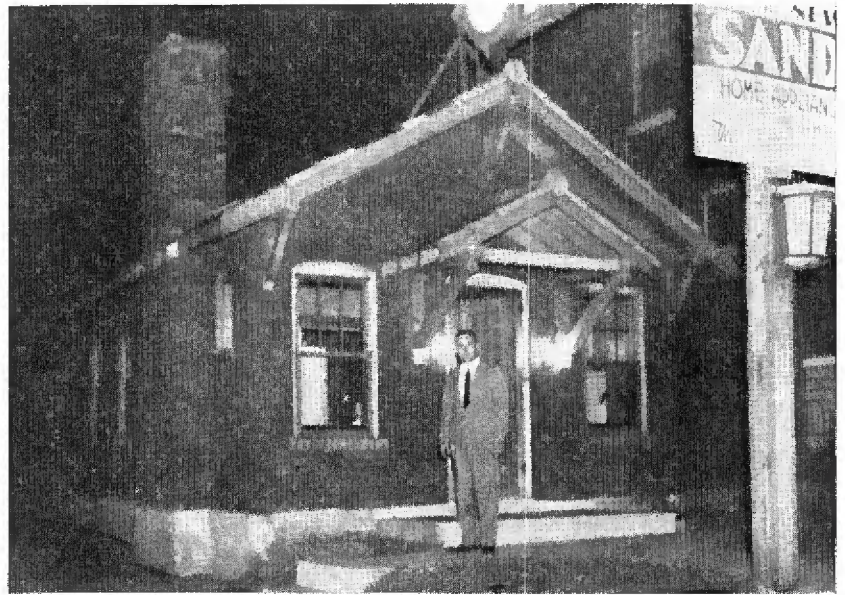

**LOW-RENT HEADQUARTERS**—Sander maintains this small bungalow-office in a low-rent area. People pay time payments here and can reach him on the 'phone. Repairs are handled in the rear and a garage is attached

from 125 to 150 people a day visiting our display. From these we glean forty to forty-five prospects who are equally good. The fact that we are doing from two to three times as much business would indicate that for a small dealer the idea is a sound one. We'll better our \$42,000 volume next year by a good deal.

### Overhead Costs Reduced

"Now then, we also shear off our costs. Up at 3552 Gravois our monthly bills were something like this:

\$175	rent
38	electric bill
10	porter
36	phone
<u>\$259</u>	a month fixed expenses

"Since we took to trailer selling August 1, our comparative costs are as follows:

\$60	rent
14.50	telephone
3.50	electric bill
<u>\$78.00</u>	a month fixed expenses

"A little subtraction will show you that we are \$181 ahead per month. Out at 3312 Kingshighway we have a big garage and a little bungalow office for receiving finance payments.

It's accessible, but not a hot retail section. With greatly improved customer contacts, and a big saving on a store, we are ahead in the game."

Inside the big garage there is space for merchandise, the trailer and a service department. Up front is a little bungalow where a girl is on duty with the books. Here is carried a stock of table appliances.

The trailer is worked from 8:30 to 12, 1:30 to 4, and 6:30 to 9. It cost \$1,830 complete, \$1,400 for trailer alone, \$250 for power plant (with a reserve of 200 watts) and \$80 for air brakes. Costs of pulling the trailer are only slightly more than running a car. As many as six salesmen accompany the caravan.

"Our approach varies," says Mr. Sander. "We play records on the public address system in poorer neighborhoods to induce people to assemble. In high grade neighborhoods, our salesmen call at homes and escort women to the machine.

Back in the days when Sander & Company depended a lot on walk-in leads, some \$150 a month was spent for advertising. Today \$35 a month is the outgo, chiefly for souvenirs that will attract people to the trailer.

Mr. Sander utters one word of

warning to dealers contemplating a trailer selling: "Don't let your men take the trailer out without a supervisor. You will find them parked somewhere enjoying a little music and klatching under some tree, and the investment is too much not to be kept working."

### Another Practical Example

As broad as the horizon is the radio store operated by partners L. A. LeSaulnier and R. E. Many. Not as the wind, but as customers listeth the firm travels over the countryside from its base at 1206 West Jefferson, Los Angeles.

Thereby the L & M Radio Company has gained customers over a five hundred mile area. This perambulating activity has built a growing business from scratch, in about two years time. Starting with a hole-in-the-wall service shop, the partners are now operating a rolling sales and service establishment, bringing their business right up to the door.

The cost: \$3800 invested in a custom-built trailer and shop equipment for same. The trailer-shop is pulled behind an ordinary coupe. It is

(Please turn to page 46)



**GOING PLACES IN 1937!**

First class accommodations now available for live refrigerator dealers who want to make money in '37.

WESTINGHOUSE,  
Refrigerator Division,  
Mansfield, Ohio



**Westinghouse  
REFRIGERATORS**





# NEWS

PEOPLE • PRODUCTS • PLANS

## STEWART-WARNER SPRINGS NEW FINANCE PLANS AT CONVENTION

Floor Plan and Special Christmas Deferred Payment Idea Presented to 69 Distributors by Brinsley of C. I. T.



**JOHN F. DITZELL**, sales manager for radio and refrigeration, takes nourishment at his company's recent shindig



**FRANK HITER**, vice-president and general manager, who spoke glowingly of 1937 sales prospects

CHICAGO—Just missing our November issue news deadline, the Stewart-Warner Corporation held its annual refrigerator convention at the Drake Hotel October 29 and 30. The company's entire distributing organization of 69 from the United States and Canada attended, most distrib-



**FRED R. CROSS**, advertising manager, revealed that the familiar black and white design was being carried over



**ARCHIE R. TILLER** of Richmond, Virginia, was high man among 1936 distributors

utors bringing along others in their sales organizations and so swelling attendance to 275.

Of great interest to distributors assembled at the Drake was the description by E. F. Brinsley (Commercial Investment Trust Corporation) of two new finance

plans. In addition to the regular finance plan of "No money down and three years to pay," with non-recourse to dealers, a new floor plan eliminating finance charges to dealers was introduced. And Brinsley further outlined a special finance plan on retail sales which permits the purchaser to buy a new 1937 Stewart-Warner refrigerator during the Christmas season on a small down-payment basis with no monthly payment due for four months.

The meeting was conducted by John F. Ditzell, refrigeration and radio sales manager, who gave the address of welcome and summarized the 1936 record of sales. The new refrigerator line, introduced at an unusually early date to permit distributors to complete sectional dealer meetings by the end of December and so start the 1937 sales campaign with a rush, was presented by C. R. D'Olive, chief refrigeration engineer, followed by J. N. Golten.

Newspaper advertising and promotion material was presented by F. R. Cross and A. B. Dicus. Hays MacFarland, of the MacFarland Advertising Agency, said that national advertising includes a weekly nationwide broadcast over CBS, featuring Horace Heidt and his "Brigadiers." F. A. Hiter, vice-president and general sales manager, announced prices of the entire refrigerator line, discount terms and advertising allowances.

### Grunow Ups Two Set Prices

CHICAGO—An increase of \$10 in the list price of its 11-tube Model 1191 receiver and its 12-tube Model 1291 has been announced by the General Household Utilities Company, effective immediately. Increase production cost is given as the reason for this rise.

The change in price does not affect 11- and 12-tube consoles, already in the higher price brackets.

### Majestic Opens Export Office

CHICAGO—Harry J. Scheel, newly appointed export sales manager for the Majestic Radio and Television Corporation, announces the opening of an export sales division office at 330 South Wells Street.

The overseas demand for the concern's merchandise, says Scheel, is highly encouraging.



### Program Locater

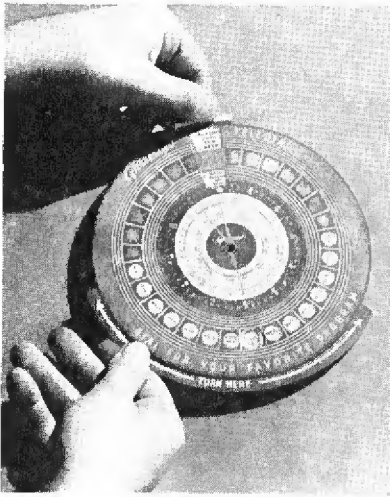

Here's Grunow's new automatic program locater, which cleverly helps popularize the company's *Teledial* at the same time. The pictures of 15 stars are included. Turn to the star's picture and the time of his program appears above, along with an advertising message.

### RMA NOISE MEETING ON

NEW YORK—As we go to press, a meeting of the Joint Coordination Committee on Radio Reception of RMA, NEMA and the Edison Electric Institute is in progress at the latter's headquarters.

Problems of radio interference, including those caused by diathermy apparatus, are being considered and a report is to be made on the interference work of the American Standards Association's Joint Committee.

### How to Popularize a Trademark



Here's the way Kay Sales dramatized the fact that it sells 6 different radio products at a party attended by 73 servicemen from Tulsa, Oklahoma, and surrounding territory, November 24

## Simplex Drops Private Brands

Will Sell Exclusively Through Jobbers Beginning January, Building National Prestige With Broadcasting, Magazines, Newspapers

SANDUSKY—From H. C. Maibohm, of the Simplex Radio Company, we learn that effective January 1, all activity in the private-brand field is to be discontinued. Maibohm's decision to drop this type of business, which has represented considerable volume, comes just as Simplex rounds out its thirteenth year of radio manufacturing and is influenced by a sharp increase in business obtained on its own trademarked merchandise through authorized jobbers.

Sales have shown a consistent increase, says Maibohm, and each year has seen the Simplex distributor organization grow, both in this country and abroad. The efforts of these distributors are to be supported by nationwide broadcasting and advertising campaigns and announcements to this effect have already gone forward to the company's field representatives. Points at which no jobber representation has yet been arranged as we go to press are expected to be covered by the first of the year.



H. C. Maibohm, who announced the new Simplex policy

### Emerson Exporter



Frank Harris, 16 years an exporter, who now does his stuff as export manager for the Emerson Radio & Phonograph Corporation

### Clarostat Hires Reps.

BROOKLYN, N. Y.—Three new territorial sales representatives are announced by the Clarostat Mfg. Co., Inc. W. W. Boes, Dayton, Ohio, will handle the Ohio territory and northern Kentucky, including Louisville. Herbert A. Roes, with headquarters in Kansas City, will look after Clarostat sales in northern Oklahoma, Kansas, Nebraska and western Missouri. And Gordon G. Moss of Greeley, Colo., will cover Wyoming, Colorado, New Mexico and western Nebraska.



**Byler Joins Kadette**

ANN ARBOR—C. A. Verschoor, president of International Radio Corporation, announces the appointment of Henry W. Byler, formerly with Philco, as Kadette production engineer.

**Clever Decal**



Amperite supplies this business-building decalcomania to its dealers, taking little printed credit. It is 5¼ by 9¼ inches overall; is red, black and white on a gold background

**Vawter With Tobe**

CANTON, MASS.—James H. Vawter of 259 North Drive, Buffalo, N. Y., has just joined the Tobe Deutschmann Corporation; will cover northern New York as factory representative.

**Radiomen Support Worthy Charity**



Paying \$100-the-couple, prominent radiomen attended a dinner given by the Federation for the Support of Jewish Philanthropic Societies at the Waldorf, November 22. Seated, left to right: Powell Crosley, Jr., A. Atwater Kent, David Sarnoff, Arthur T. Murray, James M. Skinner and B. S. Youngholm. Standing, left to right: Jules Smith, Gene Tracey, Paul Felix Warburg, A. Atwater Kent, Jr., Samuel D. Leidesdorf, Solomon Lowenstein, Henry Benjamin, Walter E. Beer, Herman Stein and Ben Abrams

**New Crosley Merch. Mgr.**

CINCINNATI—G. Earle Walker, well known in the trade for his many years of experience in the practical application of modern merchandising methods and author of many successful merchandising plans, has been appointed merchandise manager for the Crosley Radio Corporation, serving under Thomas W. Berger, general sales manager.

In his new capacity, Walker will render assistance to Crosley distributors and dealers in expanding sales activities and in setting up efficient retail sales organizations throughout the country.

**PARRIS JOINS DUNN**

CLARINDA, IOWA—C. L. Parris, who just a few weeks ago advised in a personal letter to *Radio Retailing's* Editor that he had sold his holdings in the Wincharger Corporation, relinquished his post as president and sales manager and looked forward to a long and needed shooting and fishing excursion, now comes through with a press-time flash announcing that he has become president and sales manager of the Dunn Manufacturing Company, changed its corporate name to Parris-Dunn Corporation.

Parris-Dunn, of which W. G. Dunn becomes vice-president, has had twenty years' experience in the wind-driven charger and automotive accessories field, owns patents on a control device for wind-driven mechanisms which is understood to have few parts, is not affected by snow and ice, does not rotate, adds no inert mass to the propeller, acts as an air-furl, permits complete stoppage of the machine when necessary without brakes, drags or clutches which might throw undue strain on generator shaft or bearings.

The company will in the immediate future concentrate on the business of producing wind-driven chargers which may be mounted either before or behind the mounting lever.

**Watts, New Wincharger S. M.**

SIoux CITY—W. W. Watts, former Montgomery, Ward & Company mail-order sales manager, has been appointed sales and advertising manager of the Wincharger Corporation.

He brings to the Sioux City manufacturer of wind-driven electrical generating machinery 14 years of experience in the sale and promotion of radio and electrical household appliances in farm markets.

**Hamburg Opens Swanky New Showroom**

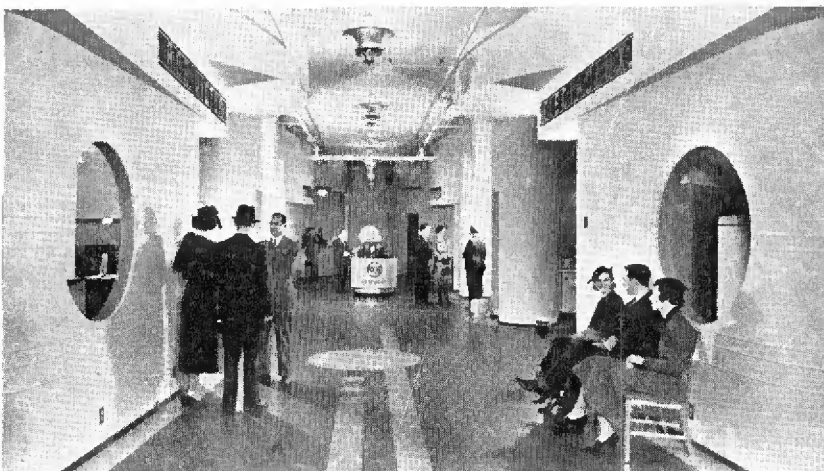

Clever use of light partitions to segregate different kinds of merchandise lends the new showroom just opened by Hamburg Brothers, Pittsburgh, an effective modernistic air



**RADIO DEALERS**

**RADIO SERVICEMEN**



Get this new radio book

**FREE**

Explains just how to spot and repair over 700 set troubles.

**Saves your time! Saves your money!**

**Time-Saving Information**

• Certain radio sets develop trouble peculiar to their particular type of circuit. Each month "Tricks of the Trade" explains how to locate and fix specific set failures. The following are examples of the easy, surest way Radio Retailing offers this vital information to you.

**BREMER-TULLY, BRUNS-WICK 55**

Bad volume control . . . Often due to fibre projecting too high, causing rotor arm to miss. Push fibre down before replacing control.

**CLARION 60, 61**

Set dead or very scratchy . . . Look for failure of special audio input transformer primary. Replace with same device or substitute resistance coupling. Tune will suffer if ordinary transformer is used for replacement due to special characteristics of original.

**CROSLLEY 143**

Noon pilot lights when set switch is in OFF position . . . Replace leaky 8 milco, 150 volt condenser.

**MOTOROLA 77**

Poor tone . . . Check to see if volume-control or field wires have been reversed. This causes volume-control form to become blackened and charred inside due to heat. If swollen, discolored appearance is noted replace.

**RCA 120**

Operates at low volume on strong signals, intermittently comes up to good volume . . . Check .05 condenser between center terminal of volume control and control grid lead of 2B7 second detector.

• Every issue of Radio Retailing will bring you more of these "Tricks". Flip them out in a short time with this FREE book you'll have a service manual of unequalled value.

**H**ERE at last is a trouble-shooting guide that will ring the bell with every serviceman and dealer in the radio game. It contains no useless description, no theories, no amateur data. Every single one of its 56-pages is packed with practical, hard-bitten "how" information that can be used profitably on your service jobs every day in the year. "Tricks of the Trade" is a service book that is different. Once you get your copy you won't part with it for a minute. This one book contains:

704 tested ways of finding and fixing the troubles in specific set circuits.

157 tube socket diagrams showing the connections for that many tubes.

Reference charts showing—the cost of electricity used in operating various appliances—the correct and incorrect way to install radio aeriels—reception spectrum—etc.

• Every one of these "tricks" (see typical examples in column to left) were volunteered by

active radio men from their own experiences. Why spend hours testing and re-testing a balky set, when with this book, you can put your finger on the most probable cause of the trouble in a few seconds.

• These "Tricks" will show you how to spot a lot of troubles that won't show up in any test equipment. If you value your time and are interested in saving yourself a lot of headaches—get a copy of "Tricks of the Trade"—today. IT IS FREE TO YOU if you accept this offer now.

**How to Get This Book FREE**

Fill in and return the order blank below with the subscription fee to cover one year of Radio Retailing for \$1 or three years for \$2 and you receive this new book—FREE—as our gift.

The book is not for sale separately. No credit orders can be accepted. Don't delay. They won't last long. Mail your order—NOW.

*Mail this coupon and payment—Today!*

**FREE-BOOK SUBSCRIPTION ORDER FORM**

**PRESENT SUBSCRIBERS NOTICE**

Present subscribers may obtain a copy of this FREE book by renewing their present subscription. Regardless of when your present subscription expires, you must send in another PREPAID renewal order. Your subscription will be extended for additional time without duplication. No previous renewal orders count. We must show a matching order for every book sent out. Mail in your order and payment today. This offer only applies in U. S. and possessions, Canada, Mexico and Central and South America. All other countries add 50c to rate to cover postage charges on book.

All books are sent out by express to insure safe delivery. There is a small handling charge of 15c—anytime in the expressman upon delivery of the book. If you prefer book sent prepaid, add 15c to the subscription fee at time of ordering.

**O. K.** Attached is \$2 for a 3 year subscription to Radio Retailing. With this order I am to get a FREE copy of the 56-page service book—"Tricks of the Trade". I'll pay the expressman 15c for delivery charges. Send the book at once. Check here  if this is renewal order.

Name..... Position.....  
Street .....

City..... State.....

Our Main Business Is.....

Check here and remit \$1 if you wish only one year subscription PLUS FREE book.

**No orders accepted without payment attached**

RADIO RETAILING  
330 West 42nd Street  
New York, N. Y.

*This offer valid after Dec. 31, 1934*

*Pin  
\$1 or \$2  
Here*



# RCA Shuffles Executive Personnel

**Bonfig Directs Victor Package Merchandise Sales,  
Deakins Handles All Other Products**

CAMDEN—G. K. Throckmorton, executive vice-president of the RCA Manufacturing Company, has announced the following appointments in the RCA Victor executive sales organization, effective immediately:

Henry C. Bonfig will direct and co-ordinate the sale of all the company's package merchandise, including radio sets, records, tubes, parts and the advertising and field administration activities.

F. R. Deakins will direct and co-ordinate the sale of all of the company's other products, including the engineering products, the International and the service divisions.

Paul C. Richardson, formerly in charge of field activities, has been appointed manager of the radio and phonograph division. Vance Woodcox, formerly central division manager, has been appointed manager of national field activities, with headquarters at Camden. Fred D. Wilson, formerly manager of the Cleveland district, has been appointed central division manager, with headquarters at Chicago. Richard Graver, formerly sales manager of the Chicago Talking Machine Company, has been appointed manager of the Cleveland district. And J. L. Schwank, formerly with Atwater Kent, has been appointed manager of the engineering products and International divisions.

E. T. Cunningham, president of the RCA Manufacturing Company, simultaneously announces election by the board of directors of N. A. Mears as vice-president in charge of purchasing and R. Shannon as vice-president in charge of manufacturing.

## D'Arcy Steps Up With Universal

DETROIT—H. A. D'Arcy, for the past year central domestic regional sales manager for the Universal Cooler Corporation, has just been made domestic sales manager. Announcement comes from F. S. McNeal, president.

## WESTON SPRINGS NEW FINANCE PLAN

NEWARK—The "Weston Investment Plan," introduced late last month by the Weston Electrical Instrument Corporation, is designed to enable servicemen to buy testing equipment necessary for modern shops without "breaking the bank."

Under the new plan the purchase price of radio test instruments may be spread into the period in which added profits are being obtained from their use in actual servicing. In addition to individual instruments such as the new Model 772, 20,000 ohm-per-volt analyzer, the investment plan will apply to special combination groups.

The new plan will be available through all regular Weston jobber representatives. Its deferred payment features correspond in general terms to automobile purchasing arrangements.

## Tone On Tap



Hook this unique tone tester to any one of GE's new radios. By twiddling its controls you can show the prospect, visually and audibly, how much better the set is than his old one. (Circuit in this month's "Service Section")

## Utah Charts Not Available

NEW YORK—Check-up charts mentioned in item "H", page 81 of the September issue, are not available and readers who have requested them are so advised. This item appeared editorially through misunderstanding on the part of *Radio Retailing*.

## FACTS . . . . .

You'll Find Them in *Radio Retailing's* 1936 Issues

Following is our index of tabular material appearing in the magazine itself during the year now ending:

**JANUARY**—Complete 1935 Sales and Saturation Statistics.

**APRIL**—Complete Automobile Radio Specifications.

**MAY**—First Quarter (1936) Sales Figures.

**JUNE**—Tube Production, By Types.

**JULY**—Complete 1936 Home Receiver Specifications.

Radio Homes By States  
January-June Set Production.

**SEPTEMBER**—Names and Addresses of Parts Manufacturers.

Test Equipment Specifications.  
Farms On Power Lines.

**NOVEMBER**—Names and Addresses of Sound Equipment Makers.



## Northwoods Magic

Mr. and Mrs. Earl C. Dockstader, up in the northwoods near Woodruff, Wisconsin, and well away from power lines, still enjoy radio entertainment over a 6-tube Zenith. A Wincharger runs the receiver, operates the 25-watt lamp and keeps a neighbor's battery up, too.





# To the v

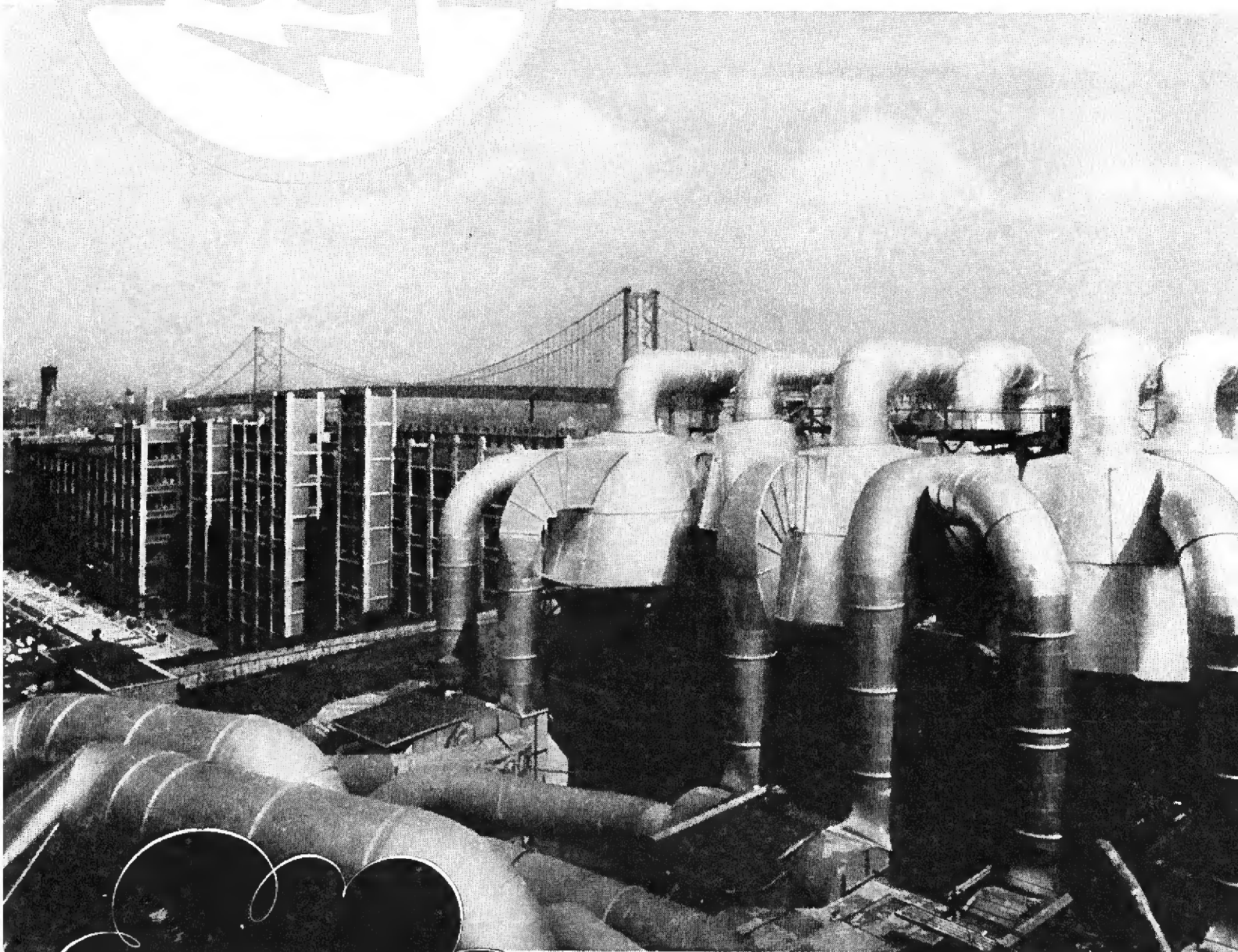

**SOUND  
ENGINEERING**

From a tiny wooden building a few feet square in which Elridge Johnson first manufactured his crude Victrola, has grown the mighty plant of the RCA Manufacturing Company at Camden, N. J., today engaged in the manufacture of every radio product from the microphone in the broadcasting studio to the loudspeaker in the home . . . giving a quality meaning to the expression, "RCA all the way."

## RADIO CORPORATION OF A

EVERYTHING IN RADIO FOR SERVICE IN C



# World's millions— *goes its radio magic!*

IF you pause to think about it, it wasn't so very long ago that "crystal sets" were the great radio rage. Earphones and cigar boxes and wires and gadgets seemed sufficient material from which to build a radio. And to faintly hear a station in a room filled with expectant quiet was really an event.

## *A Century's Progress in a Decade*

However, the giant and rapid strides forward made by the radio industry seemingly put the "old days" back centuries, instead of just a few years. It's mighty hard to believe so many startling improvements have been developed in so short a time. Radio yesterday and radio today are as different as black and white.

When this Christmas day dawns, millions will receive radios as gifts. And these instruments will make that day, and many to come, joyful and memorable. And it is through the tireless research and laboratory work, the endless experiments, the keen foresight and the *sound engineering* of RCA, that such fine radios will be possible.

## *RCA . . . and the Public*

The public knows and respects the name "RCA" in radio. And in business, such *confidence* breeds sales. Hence, dealers featuring RCA products make *more* sales. And incidentally, the approaching Christmas season and widespread publicity given the "RCA Victor-NBC 10th Anniversary Radios" both spell extra profits for dealers who will energetically push RCA Victor models.

Remember—RCA means sound engineering in radio. Some day, this organization, the only one engaged in *every* phase of the radio industry, is going to engineer *sight!*

---

RCA MANUFACTURING CO., Inc. • RCA COMMUNICATIONS, Inc.  
NATIONAL BROADCASTING CO., Inc. • RCA INSTITUTES, Inc.  
RADIOMARINE CORPORATION OF AMERICA

## These are Products of RCA Manufacturing Company, Inc.

Standard and All-wave Radio Receivers . . . Phonograph-Radios . . . Phonographs . . . Auto Radios . . . Farm Radios . . . Broadcast Station Transmitters, Microphones and Associated Equipment . . . Photophone Theatre Equipment . . . Victor and Blue Bird Records . . . Electrical Transcriptions . . . Marine Radio Equipment . . . Transoceanic Radio Equipment . . . Aviation and Police Radio . . . U. S. Government Radio Equipment . . . Centralized Sound Systems . . . Public Address Systems . . . Film Recorders . . . Laboratory and Test Equipment . . . Standard and All-wave Antennae . . . Faradon Condensers . . . Individual and Component Radio Parts and Accessories

## RCA Presents to America the Metropolitan Opera

Commencing with a special performance of "Hansel and Gretel" Thursday afternoon, December 24, and on succeeding Saturday afternoons, RCA, via the NBC Blue Network, presents a complete broadcast of Metropolitan Opera programs to the music-lovers of the nation.

Listen also to "The Magic Key of RCA" every Sunday, 2 to 3 P. M., E. S. T., on the NBC Blue Network.

AMERICA • *Radio City* • NEW YORK  
COMMUNICATIONS . . . BROADCASTING . . . RECEPTION



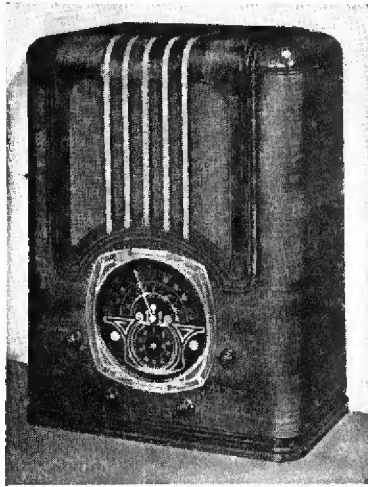

In Beauty and Performance  
—one step nearer the ultimate

ALL WAVE  
**SYNCHRO-BEAM**  
TUNING  
**9-TUBE SUPER**

Stage of R. F. on all bands;  
Provision for any type antenna;  
Six Metal Tubes; Total shielded  
receiver; Full A.V.C. on all bands;  
15 Watt Push-Pull Class "A" am-  
plification; Variable tone modu-  
lator; Split second  $7\frac{1}{2}$  inch dial,  
dual ratio; Large console chassis;  
Available in any voltage; Any fre-  
quency; Two microvolt sensitivity;  
Large 10 inch Push-Pull High  
Fidelity speaker; New design low  
minimum three gang variable con-  
denser; New large band pass in-  
termediate frequency transformer;  
Cushion mounting unit; Built-in  
phonograph Jack; 22 tuned cir-  
cuits.

Model 901B

Bands 16 to 550 meters  
110 volts—60 cycles

Table Model 901B.....\$75.00  
Chassis Model 901..... 61.50  
Console Model 901C..... 95.00

**11 Tube AC-DC Super**

Same frequency coverage as our  
9 tube AC models and the same  
general characteristics, including  
synchro-beam tuning. Over 4  
watts audio output and can be sup-  
plied in all cycles and voltages.  
11 tube AC-DC Superheterodyne 3  
band, 16 to 550 meters—American  
and foreign broadcast, and police.  
Table Models 1102B..List \$75.00  
Chassis Models 1102..List 61.50  
Console Models 1102C..List 95.00

FIFTEEN  
NEW MODELS

Send for complete illustrated catalog  
**PIERCE-AIRO, Inc.**  
512 SIXTH AVE., NEW YORK CITY

**DEWALD**

HI-QUALITY RADIOS SINCE 1921

**FAIRBANKS, MORSE**

**PLANS 1937 DRIVE**

INDIANAPOLIS—W. Paul Jones, gen-  
eral manager of Fairbanks, Morse & Com-  
pany, Home Appliance Division, announces  
that his company plans a more extensive  
and co-ordinated advertising and sales pro-  
motion program on radios, electric re-  
frigerators, washers and ironers during  
1937.

First step in the new program is ap-  
pointment of John S. Garceau as adver-  
tising and sales promotion manager, with  
Paul H. Eckstein as his assistant. Garceau  
was formerly with Kelvinator as adver-  
tising and sales promotion manager for all  
commercial divisions. Eckstein was for-  
merly with General Electric's radio divi-  
sion as managing editor of technical pub-  
lications and supervisor of national radio  
service station planning.

*With Fairbanks, Morse*

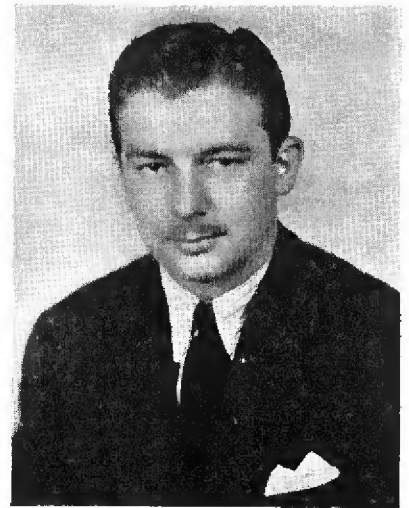

John S. Garceau, newly appointed  
advertising and sales promotion  
manager

**KELVINATOR STRENGTHENS  
FIELD ORGANIZATION**

DETROIT—Further strengthening of  
its nation-wide sales organization has just  
been announced by Kelvinator Corporation,  
of Detroit, through its vice-president in  
charge of sales, Henry W. Burritt.

Two distinct field forces will be main-  
tained, effective at once. Domestic re-  
frigeration and sales of household appli-  
ances, including washing machines, ironers,  
ranges and water heaters, will be under  
the direction of five regional managers,  
who will have all the authority of domes-  
tic sales managers located in the field,  
reporting directly to Mr. Burritt and to  
G. Strelinger, his assistant. The com-  
mercial field organization will be composed  
of seven commercial sales divisions under  
the direct supervision of J. A. Harlen,  
commercial sales manager, and will handle  
sales direction of commercial equipment,  
air conditioning and automatic heating  
products in the field.

On the West Coast both domestic and  
commercial sales will remain under one  
head.

**Ken-Rad Staff Addition**

OWENSBORO, KY.—Arthur O. Per-  
litz has joined the Ken-Rad Tube and  
Lamp Corporation as sales promotion man-  
ager, will work with C. J. Hollatz, vice-  
president and general manager, and C. C.  
Mathews, sales manager, in formulating  
sales promotion and merchandising plans  
for Ken-Rad radio tubes and incandescent  
lamps.

**Emerson Xmas Posters Appear**

NEW YORK—Twenty-four sheet size  
billboard posters recommending Emerson  
radio as the ideal Christmas gift are ap-  
pearing on the highways and by-ways of  
the nation as we go to press. The Emer-

son Radio & Phonograph Corporation re-  
leased these posters for use by its dealers  
late in November.

**New Belden Buildings**

CHICAGO—The Belden Manufacturing  
Company reports addition of 20,000 sq.ft. of  
floor space to its Chicago plant, used to ex-  
tend the wire mill and tinning plants, and  
35,000 sq.ft. to the Richmond, Indiana  
plant, used for expansion of the depart-  
ments manufacturing electrical cords.  
Cost: \$120,000.

*New Leonard Adman*

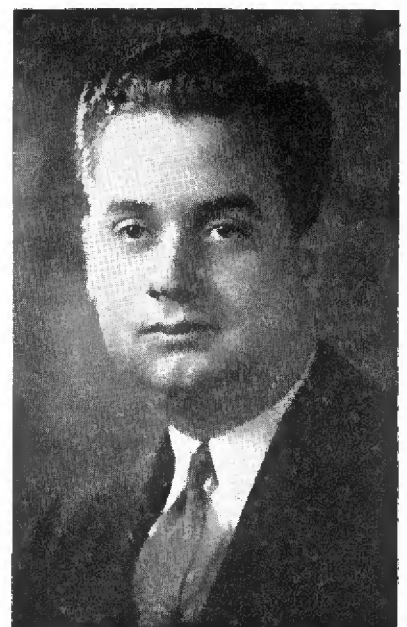

W. L. Jeffrey, who has just been ap-  
pointed advertising and sales promo-  
tion manager for the Leonard Re-  
frigerator Company. Comes from  
Kelvinator





## LIFETIME

America's Outstanding Values in  
Microphones and Sound Eqpt.

Manufacturer's

- CARBON Four-Five-Six and Seven
- CONDENSER Foot Trumpets—
- CRYSTAL Projection Baffles—
- VELOCITY Dynamic Speakers
- DYNAMIC Field Exciters
- Microphones Portable Turntables

Complete equipment for P.A. and  
Sound Men. Write for catalog of  
America's Outstanding Values.

LIFETIME CORP. 1004 Madison Ave., Toledo, Ohio

## Janette Rotary Converters

The original D.C. to A.C. converters with all wave  
filters developed exclusively for  
radio and sound apparatus.

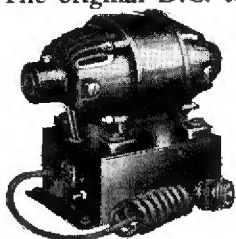

CAPACITIES:

35 to 3250 watts,  
6, 12, 32, 115 and 230 volts  
D.C. to 110 or 220 volts, 1 phase,  
60 cycle A.C.

Insist on a Janette

Ask For Bulletin No. 13-25

Janette Manufacturing Company

555 W. Monroe Street, Chicago, Ill., U. S. A.

New York — Boston — Philadelphia — Pittsburgh — Milwaukee



The deadly  
enemy of  
"man-made"  
static

• A. A. & K. licensed, im-  
placable foe of nuisance  
noises caused by electrical  
appliances near the radio  
set. No. 14, illustrated,  
lists at \$6.75. Other units  
available. NOISE-MASTER  
at various prices. In any  
proves effective on broadcast as well as shortwave bands.  
Send for complete information.



CORNISH WIRE CO., Inc. • 30 Church St., N. Y. City



The  
Number One  
Profit-factor  
in Radio Set  
Alignment

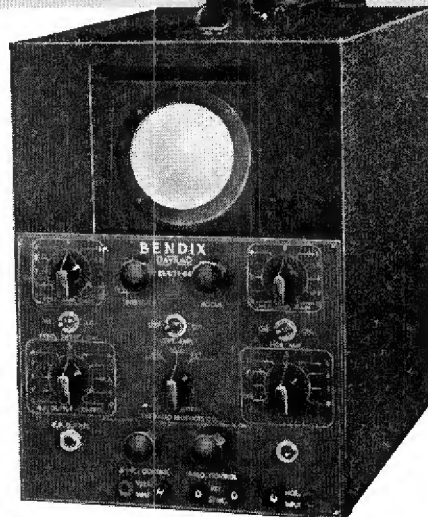

• You can check the  
alignment—and bal-  
ance—of any radio cir-  
cuit more quickly and  
more precisely with the  
Bendix-DayRad Cath-  
ode Ray Oscillograph  
than by any other  
means we know of. You can isolate the factors of unbalance, and see  
instantly the effects of your corrective measures. Any radio dealer,  
service organization, distributor, laboratory, manufacturer—has prof-  
itable use for this compact equipment.

Here's what it embraces and what its field of usefulness is:

1. The alignment of radio receivers.
2. Built in sweep circuit.
3. Built in amplifiers to adjust for the sensitivity of the receiver.
4. The measuring of peak voltage. A.C. with or without amplifiers.
5. The measuring of audio quality in audio amplifiers, therefore locating courses of distortion.
6. The measuring of modulation, percentage of transmitters, or oscillators.
7. Frequency measurements by use of Lissejou figures.
8. Checking phase shifts in various devices.
9. Study of Transient and Recurrent wave forms.
10. Testing of auto radio vibrators.
11. The adjustment of transmitters.
12. Check for power line modulation in transmitters and receivers.
13. Check for distortion in intermediate frequency amplifiers.

Send the coupon for new catalog containing full details of other  
time-proved Bendix-DayRad Radio Laboratory and Service Equipment.  
All available on Liberal Time Payment Plan.

# BENDIX DAYRAD

## CATHODE RAY OSCILLOGRAPH

(Series 64)

**\$85**  
net to dealer  
F.O.B. South Bend

BENDIX PRODUCTS CORPORATION  
(Subsidiary of Bendix Aviation Corporation)  
401 Bendix Drive, Dept. 31, South Bend, Indiana

Send me your new catalog of Bendix-DayRad Radio Service Instruments.

Name .....

Street .....

City .....

State .....

My Jobber's Name .....

## WARD STRATOSPHERE

NO. 1 AERIAL  
FOR 1937  
Model S. T. R.  
List Price \$5.00  
Fits All Cars  
Maximum  
Efficiency  
No drilling in top  
WRITE FOR CATALOG



WARD  
PRODUCTS CORP.  
Cleveland, O.

CANADA: ATLAS RADIO  
CORP., TORONTO, ONT  
FOREIGN: LINCOLN  
EXPORT CO., N. Y.

USE THIS COUPON

WARD PRODUCTS CORP.  
Ward Bldg. - Cleveland, O.  
Send information of Ward's 1937 Auto Aerials.  
Name .....

Address .....

Check  Dealer  Jobber  Service Man



# WHY TIE UP MONEY IN TUBES?

**YOU CAN  
SELL  
TUNG-SOL  
TUBES  
WITHOUT  
INVESTING  
A CENT**



Tung-Sol is the only line of high-quality tubes being sold nationally on a consignment plan requiring no investment of capital by the retailer.

There are still desirable locations where independent service organizations who can meet requirements may be appointed as Tung-Sol agents. Ask for the name of your nearest Tung-Sol tube wholesaler.

## TUNG-SOL Flow radio Tubes

TUNG-SOL LAMP WORKS, INC.  
Radio Tube Division

SALES OFFICES: Atlanta, Boston, Charlotte, Chicago, Dallas, Detroit, Kansas City, Los Angeles, New York.  
General Office: Newark, N. J.

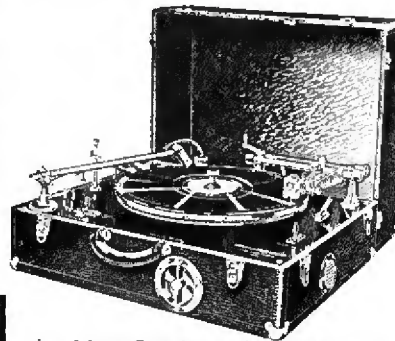

### UNIVERSAL Portable Recording Machine

A precision machined, compact outfit that positively eliminates all waver — Records in either direction at 33-1/3 or 78 R P M 90, 110 or 130 lines per inch — 110 volt AC 100% synchronous motor — solid 16 in. turntable — Constant speed rim drive — Complete switching arrangement for head set monitoring from playback or cutting head — Reinforced black leatherette carrying cases — Unequalled value — Superlative performance.

UNIVERSAL MICROPHONE CO., Ltd.  
424 Warren Lane Inglewood, Calif., U.S.A.

### The "BABYTONE"

## INSTANTANEOUS RECORDING UNIT

LIST

**\$125.00**

up  
F. D. B. Los Angeles

Four Popular Models for Home or Professional Use. Microphone included. Each Unit Complete to Record and Playback. Cuts and Grooves Acetate in one operation. Technically perfect. Guaranteed Results. No Background Noises. Simple to

operate. Write for Instructive FREE Bulletin.

A few Exclusive Territories for this profitable line are still open. Complete details to qualified Distributors.

Immediate action is Recommended. Write Dept. RR-12.

### RECORDING EQUIPMENT MFG. CO.

6611 Sunset Boulevard

Hollywood, California



**WHY FEED  
A "POWER-HUNGRY" STORAGE  
BATTERY THAT LOSES SALES  
WITH UNRELIABLE OUTPUT?**

### The EPCO STORAGE ELIMINATOR

FOR AUTO RADIO AND ELECTRICAL  
ACCESSORY DEMONSTRATION

**\$19.75**

Provides 6 volt-10 amps filtered D.C. from 110 volt A.C., instant, adjustable current to assure perfect and convincing demonstrations of 6 volt auto radios and electrical accessories. Economize by avoiding the battery-charging nuisance. Increased sales will pay for the cost within a few days. Order today for immediate delivery, or write for further particulars.

List Price

Usual

Jobber Discount

**\$15.75**

6 volt-5 amps.

**ELECTRICAL PRODUCTS CO.** 6537 RUSSELL ST.  
DETROIT, MICH.

### For Your Convenience!

—there is a handy subscription card enclosed in this issue. Use it today in ordering *Radio Retailing* at the bargain rates of:—

**1 year for \$1**

**3 years for \$2**



→ Cash With Order Only ←



# PREVIEW of NEW PRODUCTS

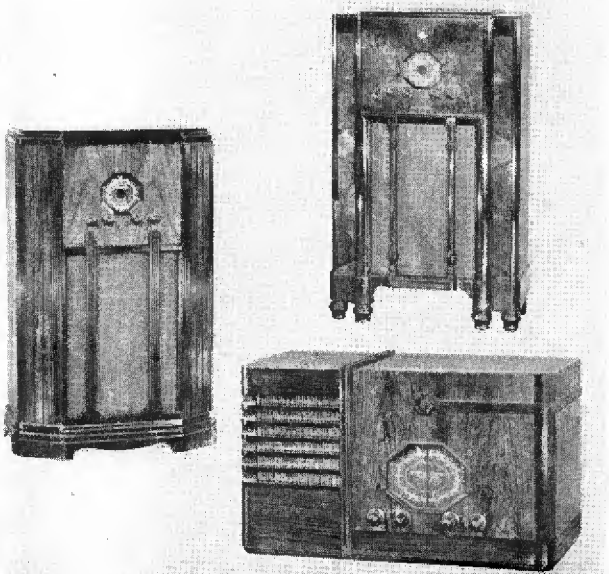

## STROMBERG CARLSON

*Stromberg-Carlson Tel. Mfg. Co., Rochester, N. Y.*

**Models:** 126-H, 126-L, 127-H, 127-M, ac-dc radios.

**Description:** Model 126, 7 tubes, three tuning ranges, edge lighted glass dial. As Model 126-H it is a horizontal table model in a cabinet similar to the 130-H with 8 in. permanent mag-

net dynamic speaker; as Model 126-L, a console similar to the 130-L, with 10-inch speaker.

Model 127, 9 tubes, three tuning ranges, push-pull amplification with a pair of 48's, edge lighted dial, Tri-focal tuning. As Model 127-H it is a horizontal table set, similar in appearance to the 140-H; while 127-M is a console similar to the 130-M.—*Radio Retailing*, December, 1936.

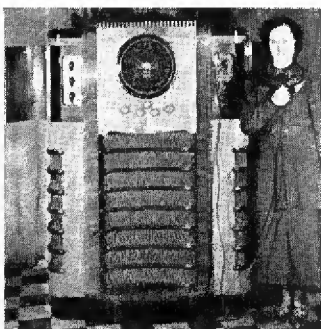

## CROSLLEY

*Crosley Radio Corp., Cincinnati, Ohio*

**Model:** 37-tube radio.

**Description:** 6 speakers; 54-18,300 kc.; power output, 50-75 watts, four chasses; Auto-Expressionator; bass compensation; six-step tone control; volume control for audio range; Mystic Hand automatic tuning. In addition to the radio re-

ceiver proper it has a public address system which has separate controls of its own. All tubes are metal with the exception of the one for the tuning light and the Auto-Expressionator tube. The cabinet is 4 ft. 10 in. high by 42 in. wide by 22 in. deep. Weight 475 lbs.

**Price:** \$1,500.—*Radio Retailing*, December, 1936.

## RAY-O-VAC

*Ray-O-Vac Co., Madison, Wis.*

**Model:** Radio "B" Power units, Nos. 55, 45, 35 and 25.

**Description:** Tops are metal with plug-in feature, standardized sizes, encased in a colorful red, blue and yellow housing.

**Prices:** \$85 to \$8.95.—*Radio Retailing*, December, 1936.

## DEWALD

*Pierce-Airo, Inc., 610 Sixth Ave., New York City*

**Model:** 522 battery radio.

**Description:** 5 tubes, superheterodyne, adaptable to all battery voltages, such as 2-volt storage, 21-volt air cell, 3-volt dry cell and 6-volt storage A battery.

A special plug in harness enables the user to connect the receiver to the current supply without the danger of connecting the set incorrectly. A special switching arrangement permits instantaneous changeover.

**Price:** \$31.—*Radio Retailing*, December, 1936.

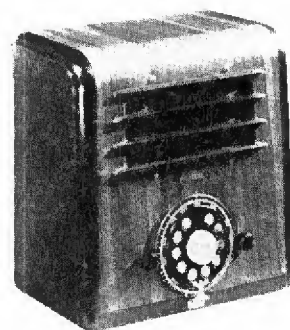

## KADETTE

*International Radio Corp., Ann Arbor, Mich.*

**Model:** Tele-Matic 35.

**Description:** Finger-tip Tele-Matic dial tuning, appearing for the first time, to our knowledge, in a table set, is available in this Model 35, just announced. Combines the simplicity of the telephone dial with the smoothness of backlash-free vernier drive.

5 tubes, a.c., superhet, 540-1875 kc., variable tone control, 5½ in. speaker.

**Price:** \$24.95.—*Radio Retailing*, December, 1936.

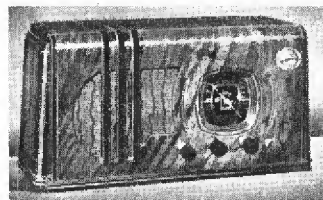

## FADA

*Fada Radio & Electric Co., Long Island City, N. Y.*

**Models:** 280CA, 265C, 265T.

**Description:** 280CA, 8 tubes, ac-dc, all-wave, superhet, console, metal tubes, "Flash-O-Graph" tuning system, 525 kc.-18.5 mc., phono-jack. With 370-145 kc. wave band, \$5 additional.

Model 265C, 6 tubes, a.c., superhet, console, "Flash-O-Graph" tuning system, 535-1570 kc. and 2.2-6.9 mc., acoustical tone chamber.

Model 265T, same chassis compact table cabinet.

**Prices:** 280CA, \$69.95; 265C, \$59.95; 265T, \$44.95.—*Radio Retailing*, December, 1936.

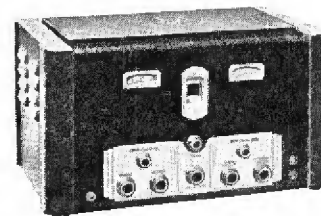

## PATTERSON

*Patterson Radio Company, Los Angeles, Calif.*

**Device:** Communications receiver.

**Description:** Model PR-16, 16 tube superhet, band spread on all bands, C.W. beat oscillator, with or without crystal filter, five bands from 550 kc. to 37 m.c., meter tuning, 3 stages i.f., heavy duty power supply, 12 in. dynamic speaker.

**Price:** In crackle finished cabinet less crystal filter, \$159.50; with crystal filter, \$169.50; console Phono-Combination, \$279.50.—*Radio Retailing*, December, 1936.

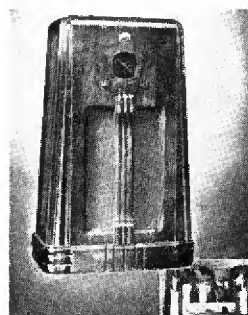



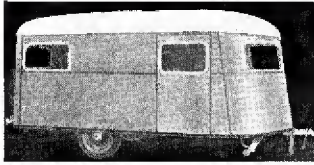

## PALACE

*Palace Travel Coach Corp.,  
Flint, Mich.*

**Model:** Trailer showrooms.

**Description:** Standard model has the following specifications: 16 ft. long, 6 ft. 6 in. wide, 7 ft. 9 in. high; 6 lb. steel channel chassis reinforced with clear white oak; special design ball and socket coupler, with positive connection, permitting full turn.

May be equipped to provide living and sleeping quarters in addition to cabinets, etc., needed for displaying merchandise. Shelving, cabinet work and other interior equipment will be installed at the factory or may be installed by the purchaser.

**Prices:** Standard, \$445; Master, \$595.—*Radio Retailing*, December, 1936.

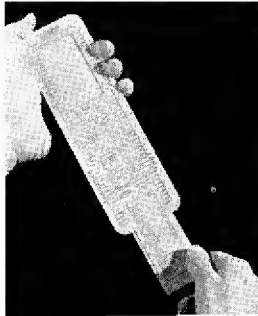

## REEKS

*W. H. Reeks, 5653 N. Talman Ave., Chicago, Ill.*

**Model:** Sliding scale world time converter.

**Description:** Exceedingly simple to operate; all readings are horizontal; instantly converts the time and date of any one country to that of any other, as well as Greenwich Mean Time (G.M.T.), to local time the world over.

To go with it is a small booklet in the same size so that the two may be kept together showing a complete list of the countries in the world with their time.

Suitable for a promotion piece or premium.

**Price:** 50c. retail. Special price to dealers for quantity orders.—*Radio Retailing*, December, 1936.

## BELL

*Bell Sound Systems, Inc.,  
Columbus, Ohio*

**Model:** Mobile p.a. system.

**Description:** For use on either a 6-volt battery or 110 a.c., making the unit suitable for inside or outside use. The change-over is accomplished by changing a jumper plug.

All controls are accessible and easily operated by the driver. Being designed especially for automobile use it is provided with an ingenious leveling device so that the turntable unit can be leveled to the exact pitch of the seat.

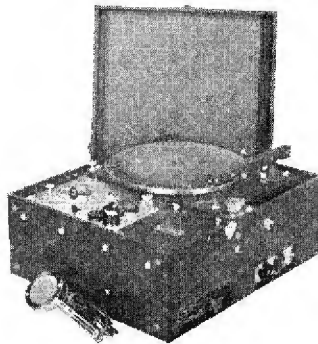

Separate power switches are provided to control the turntable motor, amplifier B supply and the amplifier filaments. Class A circuit; four stages; twin speakers.—*Radio Retailing*, December, 1936.

## TOBE DEUTSCHMANN

*Tobe Deutschmann, Corp.,  
Canton, Mass.*

**Device:** Electric razor Filterette.

**Description:** Installed between electric power outlet and the appliance plug. Universally applicable to electric shaving devices operated at any voltage up to 125 volts a.c. or d.c. Contained in a seamless aluminum housing and provided with standard attachment prongs and receptacle.—*Radio Retailing*, December, 1936.

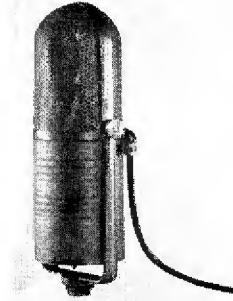

## RCA

*RCA Mfg. Co., Inc.,  
Camden, N. J.*

**Model:** Type 77-A Uni-directional microphone.

**Description:** Picks up sound coming only from one direction; uniform wide-angle response from the front; negligible response at all frequencies from the back; attenuates audience noises in theatres or large studios; can be tilted and rotated conveniently; uses but a single ribbon.

The lower half is operated on velocity principle, the upper half, pressure.

Output impedance, 250 ohms; output level (10 bar input)—69 db.—*Radio Retailing*, December, 1936.

## UNITED

*United Sound Eng. Co.,  
2233 University Ave.,  
St. Paul, Minn.*

**Device:** Sound equipment.

**Description:** Inadvertently we failed to mention in the November listing of "Sound Equipment Sources" that the United Sound Eng. Co. manufactures a complete line of fixed, portable and mobile sound systems, sound amplifiers, pickup and turntable units, microphones, speakers and horns and baffles.—*Radio Retailing*, December, 1936.

## KATO

*Kato Eng. Co., Mankato,  
Minn.*

**Models:** Diesel light plant.

**Description:** Runs on fuel or diesel oil; consumption about  $\frac{3}{4}$  pint per horsepower per hour; consists of a full diesel engine, close connected by multiple V belts to a.c. or d.c. gen-

erator. Complete unit is mounted on a welded channel steel base. Especially suited where load is 2000 watts or more. 2, 3, 5 and 6 kw.—*Radio Retailing*, December, 1936.

## IRC

*International Resistance Co.,  
401 N. Broad Street,  
Philadelphia, Pa.*

**Device:** Resistor Kits, No. 10 and 12.

**Description:** Attractive box with slide tray containing insulated resistors in the most popular ranges to simplify the problem of complete stock. Hundreds



of additional values may be obtained by combining the resistors in series or in parallel.

No. 10 kit contains an assortment of ten 1-watt "Type BT-1" insulated Metallized resistors.

No. 11 kit is similar except that it is proportionately smaller in size, containing ten  $\frac{1}{2}$ -watt resistors.

**Prices:** No. 10, \$2 list; No. 11, \$1.70.—*Radio Retailing*, December 1936.

## RADIO RECEPTOR

*Radio Receptor Co., Inc.,  
106 Seventh Ave., N. Y. C.*

**Device:** New amplifier line.

**Description:** Heavy duty amplifiers for hospitals or schools where continuous operation is necessary. All power transformers, chokes and output transformers are practically twice normal size. Frequency measurements made with input and output transformers connected in circuit. Temperature rise less than 40 degrees centigrade during operation.—*Radio Retailing*, December, 1936.



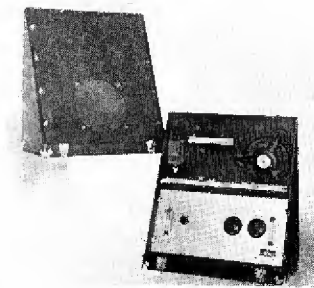

## TECHNA

*Techna Corp., San Francisco, Calif.*

**Model:** Portable public address system, 21J series.

**Description:** Class "A" 15-Watt system (25-watt peak), including crystal microphone with an adjustable floor stand which is easily converted to a hand or banquet stand type; 10-inch electro dynamic speaker; 6L6 beam power amplifier. Power input 110/125 volts—50/60 cycles; tubes, all metal types. 6J7, 2-6X7, 2-6L6 beam power, and 5Z4 rectifier; circuit—4 stage, resistance coupled with push pull power output—two 8 ohm voice coils.

**Price:** \$139.50.—*Radio Retailing*, December, 1936.

## TRIPLETT

*Triplet Elec. Instrument Co., Bluffton, Ohio*

**Device:** Model 1295 modulation monitor.

**Description:** Eliminates uncertainty of depending on the ear, variation of the antenna, or the loop and light to determine carrier shift and modulation percentage of voice transmitting radio station. Actual modulation of transmitters is shown on the direct reading dial, which has ranges from 40 to 120 per cent, all readings in peaks.

**Price:** \$24.83, net to dealer.—*Radio Retailing*, December, 1936.

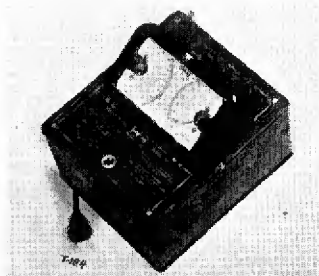

## ROTO-LOG

*Millred Mfg. Co., 757 Venice Blvd., Los Angeles, Calif.*

**Model:** Radio Log.

**Description:** Lists over 1,600 long and short wave radio stations. Its 140-in. tape contains complete information on call letters, frequencies, power, chain affiliation, etc.

In addition there is a time compensator which enables the operator to calculate instantly the



time differential at any point on the surface of the globe. This device answers such questions as: number of hours separating any two cities; local time at any point; difference between local time and Greenwich Mean Time; International Date Line complications.

Three finishes: Siris bronze, Minoan bronze, Regina walnut.

Replacement tapes are furnished from time to time.

**Price:** Bronze, \$2.50; walnut, \$3.—*Radio Retailing*, December, 1936.

## RADIO WHIP

*Donaldson Radio & Elec. Co., Inc., 1701 Grand Ave., Kansas City, Mo.*

**Models:** Radio Whip auto-radio antenna.

**Description:** Telescopic type, nickel plated steel aerial adjustable in length from 2½ to 8 ft. Easily and quickly mounted on rear bumper bracket.

Other auto-radio antennas include "Marvel Staff," a solid steel nickel 5-ft. non-adjustable type; the "Silver Streak Staff," a sectional 8-ft. pole of rustproof aluminum; and running board antennas.

**Prices:** Radio Whip, \$3.50; Marvel Staff, \$1.80; Silver Streak, \$3.00.—*Radio Retailing*, December, 1936.

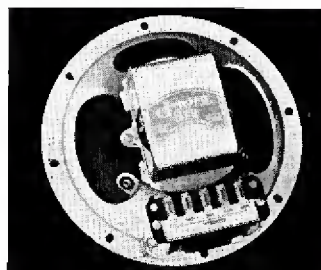

## JENSEN

*Jensen Radio Mfg. Co., 6601 S. Laramie Ave., Chicago, Ill.*

**Model:** Speakers.

**Description:** Full line of speakers with adjustable impedance transformers. With clearly marked terminal boards and impedance, adjustment is easily made with flexible lead and pin jack. No soldering required.

Two types: one to match the conventional "plate" impedance values, the other to match conventional "line" impedance values.

Jensen also is manufacturing adjustment impedance transformers only and speakers may be purchased less input transformers.—*Radio Retailing*, December, 1936.

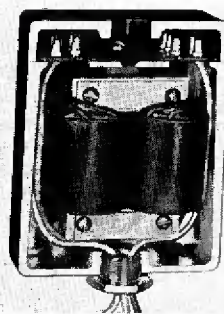

## THORDARSON

*Thordarson Electric Mfg. Co., 500 W. Huron St., Chicago, Ill.*

**Models:** "Tru-Fidelity" transformer.

**Description:** Reversible single hole mounting which permits rotation of transformer so that hum may be eliminated; case body is cast of special material and designed for maximum shielding; terminal board shield cap is ground fit; core is made of special laminated high permeability alloy; coils are dual balanced.—*Radio Retailing*, December, 1936.

## TURNER

*Turner Co., Cedar Rapids, Iowa*

**Model:** Sound equipment.

**Description:** Model S-21 system, 8-watt class A amplifier, all high gain stages, may be set up in five minutes. System includes a Master model hi-level crystal microphone, two section chrome finished adjustable stand, two 10-in. dynamic speakers.

Cabinet type sound reproducing system; constructed

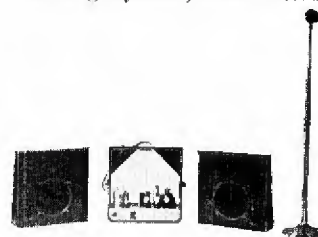

to fill the need of the individual buyer; furnished without phonograph if desired and with any number of microphones.

Sound equipment for mortuaries: Combination speech and music; extremely portable; converter available if storage battery operation is required. Many sacred recordings have been made exclusively for Turner for use with this equipment.

**Price:** S-21, \$44.25, net.—*Radio Retailing*, December, 1936.

## GLOBE

*Globe-Union, Inc., 900 E. Keefe Ave., Milwaukee, Wis.*

**Device:** Storage batteries for home power; home lighting bulbs.

**Description:** Since storage battery life is measured in cycles it is highly desirable to reduce the number of cycles of charging and discharging. These new batteries are designed principally for heavy duty, having a sufficiently large reserve capacity to reduce the necessity for recharging to once or twice a week.

Available for all type of service as well as separate radio and lighting power.

Globe Union is also in production of lamps in 15, 25 and 50 watts sizes for 6 volt lighting services. Will give light equal to similar 110 v. bulbs.—*Radio Retailing*, December, 1936.



# GREBE RADIO

Just One of  
the 40 Distinct  
1937 Models

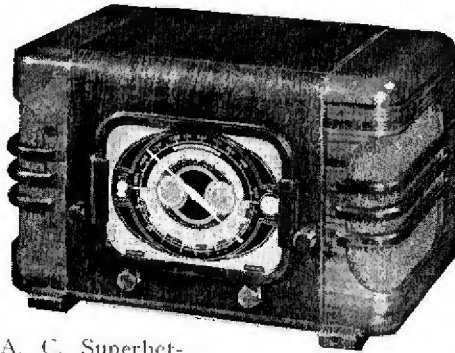

MODEL 370-C

A 7-tube, A. C. Superheterodyne. Three distinct bands: 16 to 2060 meters. Also available in 8-tube A.C.-D.C. (Model 830-C).

Polychromatic Dial Scale, Improved Vision Master, Beam Power Output Tube, 7½ inch Band Spread Magnadial and Second Hand, Automatic Volume Control and full range tone control, Automatic Band Indicator, Code Interference Filters, Octal Tube Sockets, Hair Line Selectivity, Ultra Sensitivity, Diode Detection, Multi-Voltage Transformers. 6 inch Electro Dynamic Speaker.

This handsome walnut cabinet of compact design has been especially constructed for those who desire a quality radio, but are limited as to space.

Grebe manufactures radio receivers of all voltages, all wave bands, especially designed to meet all climatic conditions anywhere.

Some exclusive territories are still available.  
Write or telegraph for details.

**GREBE MANUFACTURING COMPANY, Inc.**  
ONE-NINETEEN FOURTH AVENUE  
NEW YORK CITY Cable Address AHGREBE

BUY GENUINE

## Mueller Universal Clips

and make sure you get your money's worth



Made in Eight Different Sizes

### THE ONLY COMPLETE LINE

Steel, copper, insulated and alligator clips—from 5 to 200 ampere capacities

SEND FOR CATALOG 679 and FREE SAMPLES

*Mueller Electric Co.*

1583 East 31st Street, Cleveland, Ohio

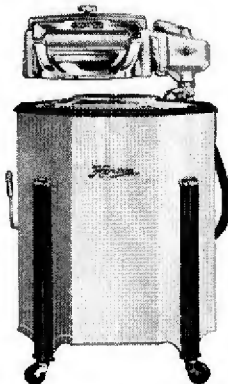

## HORTON PRECISION BUILT

Quiet, smooth-running, dependable Horton Washers eliminate service "grief" and build good will for Horton dealers. The famous "jeweled mechanism" is one of many reasons why sales of Horton washers are zooming to the highest point in 65 years of history. To increase your sales write to Horton now!

**HORTON MANUFACTURING COMPANY**  
3606 OSAGE ST. FORT WAYNE, IND.

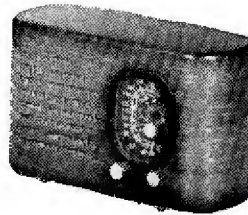

SIMPLEX

*Simplex Radio Co.,  
Sandusky, Ohio*

Models: 1937 line of radios.

Description: Model Z, 4 tubes, ac-dc, 550-1750 kc., illuminated airplane dial.

Model RJ, 6 tubes, ac or ac-dc, triple purpose metal and glass tubes, 540-1750 and 2250-7300 kc., large illuminated dial, 5 in. dynamic speaker, avc.

Model D, comes in deluxe upright table, compact and console cabinets, 7 tubes, ac-dc, magic eye, metal and glass tubes, 540-

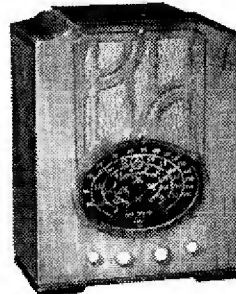

SPRAGUE

*Sprague Products Co.,  
North Adams, Mass.*

Device: Uncased paper section, cardboard dry electrolytic condensers.

Description: Improvement in design makes these units excellent as compact transmitting units as well as for a wide variety of service replacement purposes. Instead of the rough unfinished cases previously supplied, these new type UC condensers are fully cased. They are constructed with the recently developed moisture-proofing process. No increase in price.—*Radio Retailing*, December, 1936.

## TECHNA

*Techna Corp., 926 Howard St., San Francisco, Calif.*

Models: P. A. equipment.

Description: Techna was omitted in error from the November listing of public address equipment sources. They make a line of complete systems for fixed, portable and mobile use, centralized sound and radio systems, inter-office call systems, p.a. amplifiers and tuners, and combination pickup and turntable units.—*Radio Retailing*, December, 1936.

1750 and 5500-20,000 kc. plus 2450 kc. police, 6½ in. speaker. Also available for 2, 6 and 32 volt operation.

Model G, 9 tubes, magic eye, metal and glass tubes, 540-18,000 kc. Comes in upright table and console cabinets for ac, ac-dc, 6 and 32 volt operation.

Model NT, 11 tubes, metal and glass tubes, 540-19,000 kc., upright table or console models.

All Simplex radios above are available with long-wave band at slight additional cost.

The Sportsman, 4 tube portable battery superhet, 540-1750 kc., avc, PM 5 in. speaker.

Prices: Z, \$12.25; RJ, \$19.95; D deluxe table, (ac-dc or 2 volt) \$29.45; D compact, \$27.45; D console, \$37.45 (6 volt D models, less batteries, add \$7.50; 32 volt, add \$9.50); G table, (ac or ac-dc) \$36.95; G console, \$39.95 (add \$8.50 for 6 volt and \$10.50 for 32 volt prices, less batteries); NT table, \$49.95; NT console, \$69.95; Sportsman, \$26.50, less batteries.—*Radio Retailing*, December, 1936.



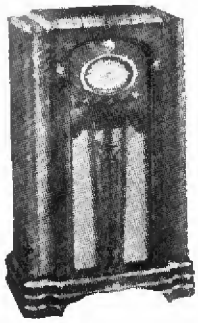

### GREBE

*Grebe Mfg. Co., Inc.,  
119 Fourth Ave.,  
New York City*

Model: 411OE.

**Description:** 11 tubes, a.c., 4 bands (16-555 and 870-2060 meters), Centro-Master automatic control unit, improved Vision Master, polychromatic dial scale, band spread Magna-dial and second hand, Uni-control two speed free wheeling tuning, equitone bass compensation, r.f. preselector stages on all bands, avc, octal tube sockets, 12 in. high fidelity speaker.—*Radio Retailing*, December, 1936.

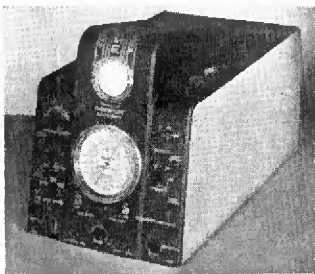

### SUPREME

*Supreme Inst. Corp.,  
Greenwood, Miss.*

**Device:** Diagnomoscope.  
**Description:** Model 555, a complete, self contained cathode-ray instrument with built-in audio oscillator and frequency modulated signal generator. A linear saw tooth oscillator employing an 885 gaseous discharge tube has a range of 7 to 20,000 cycles, amplifier response is practically flat from 20 to 90,000 cycles.  
In special crackle finished cabinet with transparent screen calibrated in k.c. off resonance to facilitate receiver alignment.  
**Price:** \$147.95 net.—*Radio Retailing*, December, 1936.

### HAMMARLUND

*Hammarlund Mfg. Co., Inc.,  
424 W. 33d St., New York City*

**Device:** "Super Pro" receiver.

**Description:** Using a combination of 8 metal and 8 glass tubes for maximum efficiency, this new professional receiver incorporates the latest circuit design. Variable band-width control calibrated in k.c. permits selectivity ranges from a band-width of 3 k.c. to 16 k.c. by adjustment of a knob on the panel. The c.w. beat oscillator is also calibrated, likewise the audio gain. Anyone of five bands, from .54 to 20 mc., can be received with either

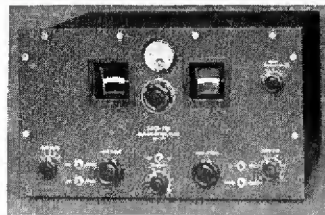

high fidelity or extreme crystal filter selectivity. Noise level on 14 mc. is 8 db. at 7 microvolt input. Audio amplifier flat within 2 db. from 50 to 10,000 cycles.

**Price:** From \$405 to \$497.50.—*Radio Retailing*, December, 1936.

### AMPERITE

*Amperite Corp.,  
561 Broadway, New York City*

**Device:** Amperite a.c.-d.c. ballast tube.

**Description:** Equipped with a new patented starting resistor which prevents overloading of tubes and pilot lights when the set is first turned on. The starting resistor allows only approximately 70 volts on the set at the initial surge instead of 115, the statement reads. It can be used with one or two pilot lights, of either .150 or .250 amperes type.—*Radio Retailing*, December, 1936.



# BUSINESS IS BOOMING!

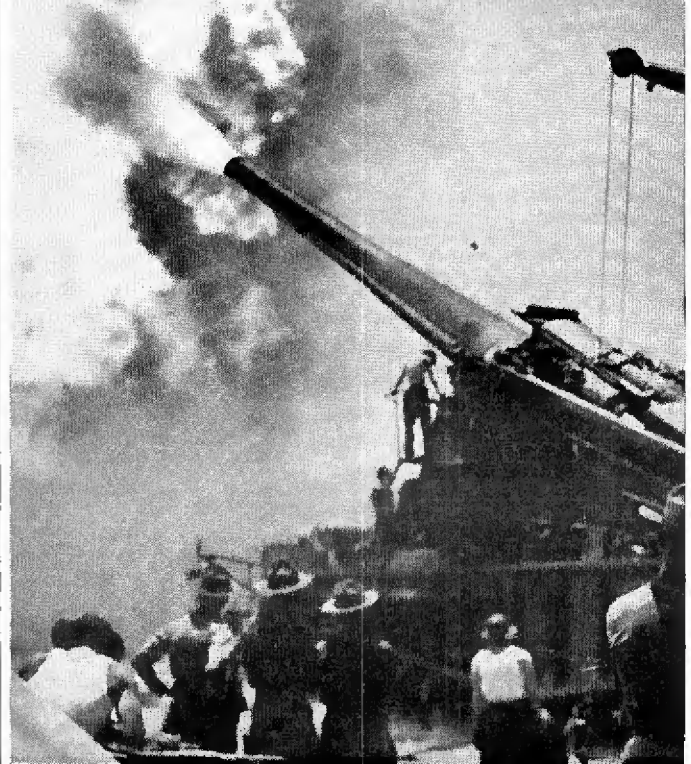

## ... AND IT'S BOOMING BEST FOR THE DEALER WHO SELLS SYLVANIA TUBES

● Is your tube business bringing you a growing list of pleased, dependable customers? Is it bringing you good will, mounting profits, and the kind of business that will stand up under any depression?

Sylvania can bring you that kind of business! For you can always depend on Sylvania quality. Before any Sylvania tube reaches your shop... *eighty separate tests* have been made for your protection. Sylvania means fair list prices... a six months' guarantee on every tube... valuable technical and sales helps from engineering and promotional departments that are always on their toes!

Start your tube business on a safer, more profitable basis NOW! You can get FREE... complete sales and technical information by writing to the Hygrade Sylvania Corporation, Emporium, Pa.

# SYLVANIA

THE SET-TESTED RADIO TUBE



## STORES ON WHEELS

(Continued from page 29)

twenty feet long and has an overall weight of 5,300 lb., including equipment. The partners' travel-log, too, shows that it costs but very little more to pull the trailer than to run an automobile. Equipment consists of regular repair kit, a 1500 watt a.c. power plant, operated by a 3 hp. gasoline motor, and a public address system.

### Small Town Sensation

In smaller towns, particularly, are the partners' selling methods sensational enough so that the trailer itself is the chief selling point. In initial promotions outlying small towns were visited so that each town would be "hit" on Saturday or Sunday—when everyone was in town. The beautiful, all-steel job rolled up and down the main drag, the public address system broadcasting records with an occasional pause for an announcement of radio service. The "store" was then parked near the center of town. Native curiosity did the rest. Coming up to examine the equipment, inhabitants of the town

remembered their radios. Contact for servicing was established forthwith.

Isolated farm houses were also canvassed as the trailer rolled from town to town. Many farmers became immediate customers because they could obtain right-now service, whereas formerly it had been necessary to take their radios into town and leave them for servicing. The L & M Service meant that they need lose no time from the air. This, briefly, was the prime reason why the idea proved successful in outlying communities.

### In The City Too

Why not, reasoned the partners, try the same idea in Los Angeles? Although radio service establishments are to be found there in great abundance, the city dwellers liked the instantaneous service that was afforded and shortly regular routes were built up in the metropolitan area—in residential sectors because the trailer's bulk makes it impossible to find parking places in the downtown sections.

Shortly routes were expanded. Now there are as many as five cus-

tomers in one block, all being serviced by the radio trailer. One great selling point that is stressed is the fact that everything is open for customer-inspection. The trailer is fitted out with comfortable leather chairs so the radio owner may come in, sit in the service shop and watch the repairman work on his radio.

Business has gradually become concentrated in heavily populated areas. The partners have all they can do to keep up with service calls in and around Los Angeles, although the field business is so profitable that about three circles per month are made into outlying communities. Customers have learned to await the arrival of the repair-trailer so the five hundred mile swing reaps results.

About ten demonstrations are given weekly and most of them end with a sale. Floor traffic is greater than if the firm depended upon a store and the operation is not burdened by the costs of a high rent district.

L & M started out with service only but its contacts automatically offer so many opportunities for selling that a line of sets has just been added. Obviously, this business of putting stores on wheels will spread.

# DUMONT

## World's Finest CONDENSERS

**THE ONLY  
ELECTROLYTIC  
CONDENSER  
GUARANTEED  
FOR  
2 YEARS**



9 Millions  
in Use  
all over the World.

*The following features  
prove the superiority of 5  
DUMONT Condensers.*

- Low leakage.
- Small size.
- Low power factor.
- Licensed under U. S. Patent No. 19,604.
- Self-healing.

- Long life. (Guaranteed for 2 years.)
- Individually packed in neat silver fibre cartons.
- Available in all capacities and voltages.

**DUMONT ELECTRIC COMPANY, Inc.**  
514-516 Broadway New York City  
*If your jobber cannot supply you write us.*

## ORDER YOUR NEW VOLTOHMMETER-OUTPUT METER TODAY!

This newest addition to the Burton line of test equipment combines a reliable VOLTOHMMETER with a two scale output meter and will find a multitude of uses in the hands of the service man.

### Features

1. Large 3 inch meter with two color dial. Accurate D'Arsonval movement with knife-edge pointer—zero adjuster provided.
2. All ranges 1000 ohms per volt. D.C. Volts: 0-10, 0-250, 0-1000. D.C. MA: 0-1, 0-10, 0-250.
3. Two direct reading ohm scales; LO-OHM from 1/2 to 500 ohms, HI-OHM from 200 to 500,000 ohms.
4. Two output scales—one for voice coil circuit; one with blocking condenser.
5. Ohm zero adjuster compensates for battery voltage and controls output scale.
6. Rugged bakelite case 6 1/2 x 3 3/4 x 2 3/8 inches with clearly marked panel and selector switch.

A good VOLTOHMMETER and OUTPUT METER is necessary for accurate testing on the job or in the shop. Good tools shorten labor. Order your VOLT-OHMMETER today. Price \$13.50, net with battery.

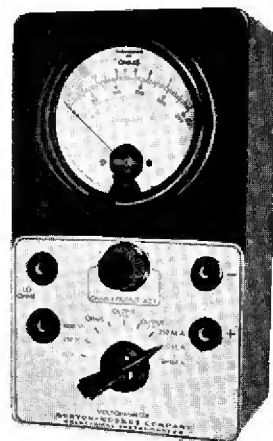

**THE BURTON-ROGERS CO.**  
755 BOYLSTON ST., BOSTON, MASS.



Page Missing  
From Original

(probably a tear-out page)



Page Missing  
From Original

(probably a tear-out page)



# NEW APPLIANCES

USE THE CARD ON PAGE 66 TO OBTAIN MORE INFORMATION

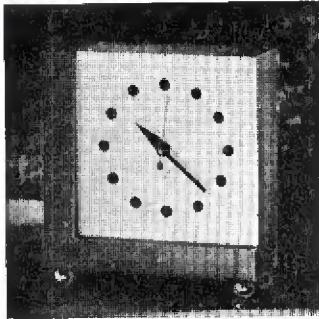

MILLER

48 *Herman Miller Clock Co.*

**Models:** Electric clocks.

**Description:** Smart styling characterizes the line of electric clocks which are made in a variety of modernistic styles.

Simple forms, gleaming surfaces and sweeping lines have been used to emphasize the quiet elegance of simplicity. Dots in place of numbers add a new touch in many of the models. Many are of ultra-modern lines but there are several of conservative designs, although all are modernistic in trend. Black and silver have been used extensively.

**Prices:** \$4.50 to \$25.—*Radio Retailing*, December, 1936.

## KELVINATOR

49 *Kelvinator Corp.*

**Models:** Electric ranges and water heaters.

**Description:** Ranges—five standard and four special models ranging in size from the small compact type for kitchenette to the large cabinet models. White



table top of stain-resistant porcelain; Economy Cooker; oversized ovens; temperature control; convenient outlet, self-closing oven door, oven signal light.

Water heaters — keep abundant supply of hot water constantly on hand automatically; all electrical parts are easily accessible for inspection or adjust-

ment without draining the tank. Only three principal parts to the water heater: heavily insulated tank, element and thermostat, all built into one unit.—*Radio Retailing*, December, 1936.

## GENERAL ELECTRIC

50 *General Electric Co.*

**Model:** "Time Saver" washing machine.

**Description:** Activator washing action, electric pump, heavy-duty Lovell



wringer with instant release, 7 lb. capacity tub with convex rim which acts as a splash guard. Washer mechanism is permanently lubricated at the factory and never requires oiling.—*Radio Retailing*, December, 1936.

## SUPERIOR

51 *Superior Elec. Products*

**Models:** Waffle irons, toasters, electric irons, sandwich toasters, hot plates, heaters, percolators, curlers.

**Description:** Complete line of electrical appliances, all of modernistic design.

The "Signal Light" electric iron is so named because a signal light shows instantly whether or not the current is on.

Serving set consisting of a walnut tray, glass dishes, etc., available for the toasters and sandwich grills.—*Radio Retailing*, December, 1936.

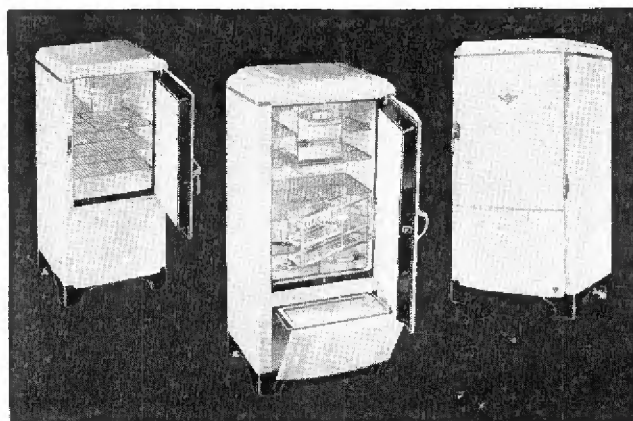

## STEWART WARNER

52 *Stewart Warner Corp.*

**Model:** 1937 line of refrigerators.

**Description:** Three Master and eight deluxe models. Four of the latter have porcelain exteriors. Cubic foot capacity deluxe models: 5.64, 6.3, 7.4 and 8.1. Master models: 4.5, 5.64, and 6.3.

The exterior appearance of the cabinet has been changed and restyled. Particular emphasis is laid on six features: improved Sav-A-Step, new automatic Slid-A-Tray, 16-point large illuminated airplane type

cold control, reversible evaporator door, vapor sealed cabinet, twin cylinder Slo-Cycle compressor.

A new note is apparent when one opens the door of a deluxe model for color has been added to the interior. Surrounding the cold control dial is a striking panel of jade green Tenite. The handles on the sliding vegetable and fruit drawers are also of Tenite as are the handles of the evaporator door, and the button for the automatic slid-a-tray.

Rubber ice trays, double depth trays, four-piece Kontanerette, Tilt-A-Shelf are to be found in the deluxe models.—*Radio Retailing*, December, 1936.

## AEROVOX

54 *Aerovox Corp.*

**Device:** Replacement capacitors for refrigerator servicing.

**Description:** Greater variety and more precise choice now offered. Many exact duplicate replacement capacitors have again been added to an already extensive line.—*Radio Retailing*, December, 1936.

## HORTON

55 *Horton Mfg. Co.*

**Model:** Kleen Zoning principle on washers.

**Description:** Tub can be freed of all sediment or silt with the Kleen Zoning brush, leaving it clean, for the next washing.—*Radio Retailing*, December, 1936.



APEX

53 *Apex Rotarex Corp.*

**Models:** 105 and 141 cleaners.

**Description:** Model 105, glove fitting handle, Presto-toe nozzle adjuster, nozzle height indicator, forward rotating brush, rubber bumper, 1/5 hp. Apex ac-dc motor.

Model 141, hand cleaner, comfortable fitting handle, toggle switch, Apex motor which operates on a.c. or d.c.—*Radio Retailing*, December, 1936.



STARTING IN JANUARY

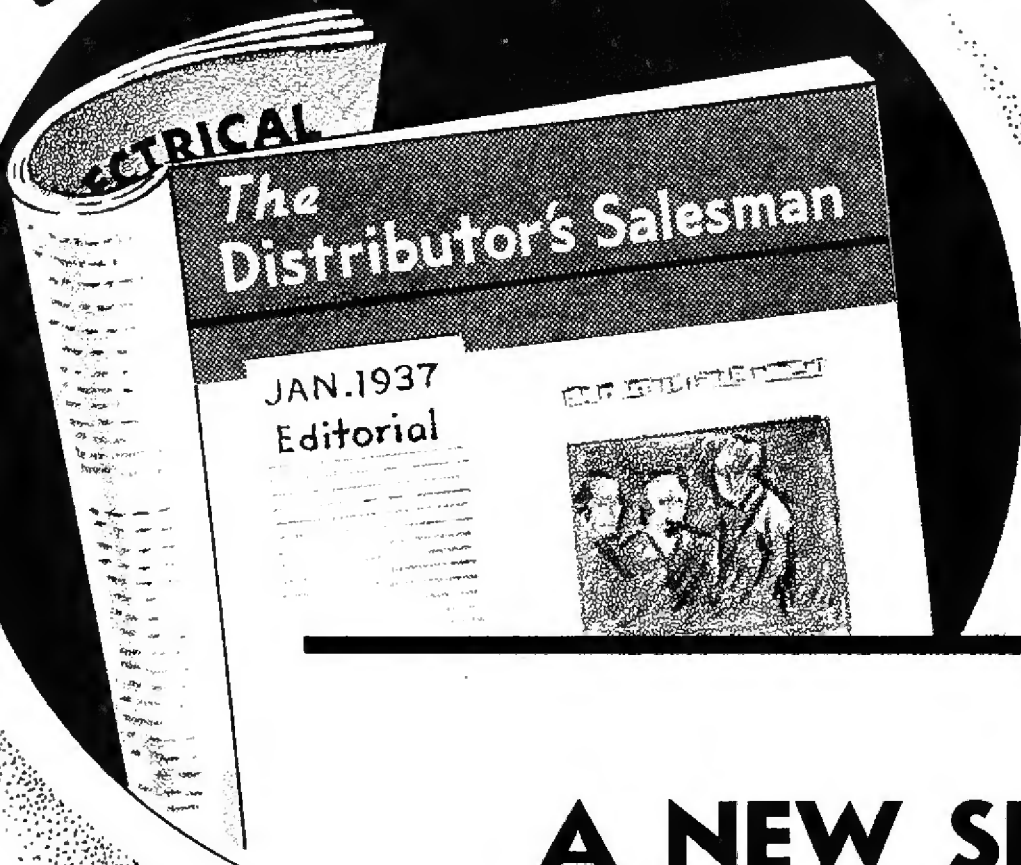

## A NEW SERVICE

for aiding radio manufacturers to gain adequate distribution and increase sales from present distributors

Starting in January, there will be available for the first time a service that covers the entire field of electrical wholesale distributors and their salesmen.

This new service will be devoted entirely to radio and electrical appliances. It will be published monthly as a separate section bound into **ELECTRICAL WHOLESALING**, the magazine of electrical distribution, and will reach 1,000 electrical wholesalers and their 4,000 salesmen (prac-

tically all of whom sell appliances), and 3,000 specialty distributors and their salesmen.

The advantages that this new publishing service offers radio and appliance manufacturers are too numerous to outline here. We urge you to write for our booklet which gives complete details.

### **ELECTRICAL WHOLESALING**

*A McGraw-Hill Publication*

330 W. 42nd ST., NEW YORK, N. Y.



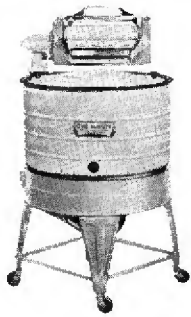

ONE MINUTE

56 *One Minute Washer Co.*

**Models:** Washers.

**Description:** Eight styles and sizes in the line. Features available: Leverless aluminum wringer, controlled from top bar; automobile body steel frame and legs, giant Hi-vane bottom aluminum agitator; deluxe safety push release wringer with convenient automatic tension reset lever and deluxe feed apron. Simplicity and dependability have been built into the new One Minute gear case which has only five moving parts. Motor, Westinghouse  $\frac{1}{4}$  hp.

A gasoline engine model with Briggs-Stratton four-cycle engine mounted on sturdy strap iron base is also available.—*Radio Retailing*, December, 1936.

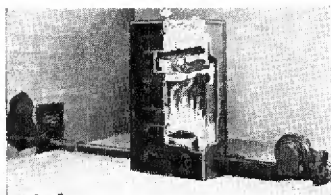

AUBURN

57 *Auburn Foundry, Inc.*

**Model:** Type DLD stoker.

**Description:** For all sizes of warm air furnaces and boilers, suitable for 300-900 ft. of net radiation or where the annual coal consumption is from 7 to 18 tons, depending on the kind of coal and nature of the load. Equipped with a cast iron silencer over the fan intake, in which also is installed an automatic draft damper. Line drive, feeds from bin to burner.—*Radio Retailing*, December, 1936.

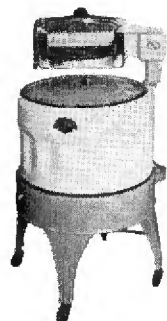

GENERAL ELECTRIC

58 *General Electric Co.*

**Model:** "Comet" electric range.

**Description:** "Unitop," top and back splash in one piece; "No Stain Vent"; single touch closes door; 16x17x18 in. oven; large storage space; porcelain front; three Calrod cooking units—2100, 1200 and 1000 watts. Thrift Cooker is standard equipment. Appliance receptacle on back splash so appliance cord is out of the way. Fuse protecting the receptacle may be conveniently reached.—*Radio Retailing*, December, 1936.

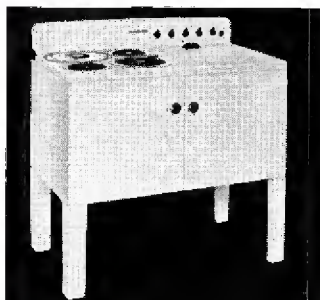

BARTON

59 *The Barton Corp.*

**Models:** Washers and ironers.

**Description:** Washers; patented water action providing "1710 extra water currents a minute" is featured. Available in three of the six models. All models are attractively designed with special attention given to pleasing colors. Lovell wringers are used exclusively and emphasis is placed on safety features incorporated in these wringers. The Barton step-up of prices is carefully planned to create quickly visible and easily justifiable differences for each step in price.—*Radio Retailing*, December, 1936.

# The TUBE of the YEAR

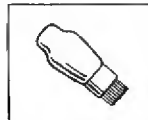

Millions of Arcturus GLASS Tubes, used initially in radio receivers, create a natural replacement market for Arcturus Dealers and Servicemen.



Millions of "G" Tubes of Arcturus manufacture are in use today. Here is a big replacement market for you.



The active demand among manufacturers and public for the Arcturus CORONET — the tube developed as an advance over the metal tube — is a further tribute to Arcturus quality.



And Arcturus CORONETS FOR REPLACING GLASS TUBES are new, exclusive, made-to-order to boost your sales and profits.

Specifications for 1937 Sets show that the majority of next year's radios will be G-Tube equipped.

When you realize that ARCTURUS was first with the "G" Tube — introducing it in April, 1935, a full year ahead of other manufacturers — you get a clearer picture of the part Arcturus plays in the forward march of radio progress.

ARCTURUS' continued pioneering achievements are significant to radio dealers and servicemen because it is their best assurance that with ARCTURUS they will keep a step ahead of the procession.

As evidence of this progressive policy, ARCTURUS is the ONLY line which offers you the 4 types of tubes set owners ask for today — the GLASS tube, the "G" tube, CORONET, and CORONET for replacing glass tubes.

For further information as to WHY IT WILL PAY YOU TO STOCK ARCTURUS IN '37 see your jobber or write:

Arcturus Radio Tube Co., Newark, N. J.

# ARCTURUS

GLASS — "G" — CORONET  
RADIO TUBES





# Now! A.V.C. Testing Simplified

with **TRIPLETT**  
 MODEL 1200-C  
**VOLT-OHM-**  
**MILLIAMMETER**



MODEL 1200-C

A. V. C. (Automatic Volume Control) places automatic bias voltage on the grids of the I. F. tubes. Voltage varies with signal strength. Test is made by measuring diode, comparative voltage or value of resistance.

All this can be done simply and quickly with the new Triplett Volt-Ohm-Milliammeter Model 1200-C.

Model 1200-C has:

Separate A. C. and D. C. instruments in twin case with tilting for accurate reading. Ohms scales separately adjusted. Low Loss switch. (Contact error less than 1/2%). Low Ohms scale requires but 6-2/3 milliamperes. Accuracy both A. C. and D. C. guaranteed within 2%. All Metal Case.

Scale Reads: D. C. 10-50-250-500-1000 Volts at 5,000 Ohms per volt; 250 Microamperes; 1-10-50-250 Milliamperes; 1/2 to 500, backup circuit; 1500 Ohms; 1.5 and 7.5 Megohms; A. C. 10-50-250-500-1000 Volts.

**DEALER PRICE \$24.33**



5,000 Ohms per Volt D. C.



Resistance reading to 7.5 Megohms



For all radio measurements not requiring a no current draw Vacuum Tube Voltmeter

A TRIPLETT MASTER UNIT

SEE YOUR JOBBER — WRITE FOR CATALOG



The Triplett Electrical Instrument Co.  
 2012 Harmon Drive, Bluffton, Ohio.

Without obligation, please send me more information  
 on Model 1200-C.

Complete Triplett Master Unit Line.

Name .....

St. Address .....

City ..... State .....





# NOW... RADIO SERVICING IS MORE PROFITABLE EASIER



MODEL  
740  
DEALER PRICE  
**Only \$18.60**

WITH  
**RANGER  
EXAMINER**

VOLT-OHM-  
MILLIAMMETER

AVAILABLE NOW IN SINGLE TESTERS ALSO COMBINATIONS TO SUIT YOUR NEEDS

## EYE APPEAL...PRECISION ACCURACY

YOU AND YOUR CUSTOMERS WILL APPRECIATE THE UTMOST IN PROFESSIONAL APPEARANCE

Yes, Ranger-Examiner Equipment definitely means that Radio Service work can be done more profitably and easier. More profitably because considerably less money is required for precision equipment, and easier because Ranger-Examiner is a completely new line designed from scratch with all the latest improvements for quick and accurate service. Less weight, too, to carry around in sturdy all-metal cases.

Ranger-Examiner testers are manufactured by the oldest company in the service equipment field whose contacts make them fully acquainted with the needs of the radio serviceman.

Model 740 Volt-Ohm-Milliammeter has a

Triplet 3" square Precision Instrument. Scale readings: 10-50-250-500-1000 A.C. and D.C. Volts at 1000 Ohms per Volt (D.C. Accuracy 2%; A.C. 5%) 1-10-50-250 D.C.M.A.; 0-300 low ohms; high ohms to 250,000 at 1.5 volts. Rheostat adjustment for 13½ volts for ohm readings to 2.5 megohms. Batteries may be added permitting higher resistance readings in 250,000 ohms steps. Low Ohms to ½ Ohm—with 25 ohms in center of scale. Backup circuit used. Current draw is only 1 M.A. . . . Compare First . . . Then Buy Ranger-Examiner.

Be sure to send Coupon for your FREE copy "101 Radio Troubles and Their Cures."

Get this

**FREE  
BOOKLET**

LISTING 101 MOST  
FREQUENT RADIO  
TROUBLES



**HOW TO DETECT  
HOW TO CURE**



**NOTHING LIKE IT BEFORE  
GREATLY SIMPLIFIES  
EVERYDAY SERVICE**

**SEND  
COUPON  
NOW . . .**



**RANGER  
EXAMINER**

Readrite Meter Works  
1220 College St., Bluffton, Ohio

Without obligation please send me your free Booklet, "101 Radio Troubles and their Cures," and complete Ranger-Examiner Catalog.

Name .....

St. Address .....

City ..... State .....







## Tone Tester

In order to demonstrate the advance in tone qualities of their new receivers over those on the market a few years back, G. E. uses a novel filter attachment.

A system of capacity, inductance and series resistance in a number of

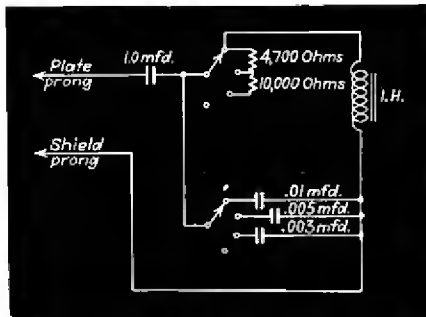

different combinations are shunted from the audio plate to ground. By selecting a chosen value of these components according to the rotation of a pictorial display, a reproduction of the tone of models from 1926 to 1936 is obtained.

The shunt capacity cuts off all the high notes, giving a boomy effect. The series resistors tend to reduce the lows while the inductance causes a sharp peak to develop in the frequency range.

## Grid-Controlled "Eye"

Since the introduction of the tuning eye little has been done to improve performance except for the more universal sensitivity characteristics of the 6G5. Raytheon has recently developed the 6H5, which offers considerable improvement in control, intensity and longer life.

In the 6E5, 6G5 and 6H5, when a positive potential is applied to the control grid of the triode section, an increase in plate current takes place. However, since the plate is joined externally to the target, a drop in plate current results. This makes the shadow control electrode, which is joined directly to the plate, less positive than the target. Therefore, this electrode

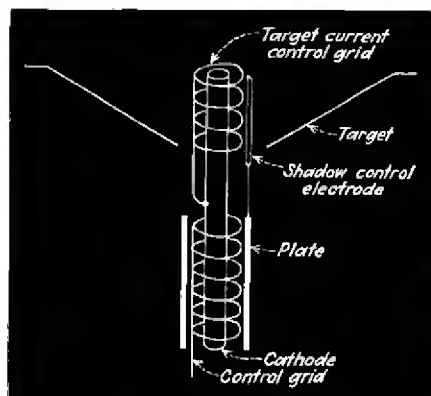

exercises a similar control over the flow of electrons from cathode to target as the usual grid of a tube, cutting out a portion of the eye, more commonly known as "opening of the eye." The less positive this electrode is, the greater the eye opening.

However, in the 6E5 and 6G5 the target current, which causes the illumination is limited only by the omission saturation of the cathode. This current, with age and increases in line voltage, rises to very high values at times, sufficient in some cases to damage the tube or even the set itself.

In the 6H5 a control grid is placed around the cathode and tied to it. This grid is of such construction as to limit the target current to a safe value. By so doing, the 6H5 becomes a universal tube for A.C. or A.C.-D.C. use in that voltage variations in the line will not affect the tuning or brilliance of the eye.

## New Tubes

**913** Cathode ray tube with a one inch screen. Suitable for any application for which the larger tubes are used.



High-Voltage Electrode (Anode No. 2) voltage	500
Focusing Electrode (Anode No. 1) voltage	125
Grid voltage for current cut-off	-90
Peak voltage between Anode No. 2 and any deflecting plate	250
Typical operation:	
Heater voltage	6.3 6.3
Anode No. 2 voltage	250 500
Anode No. 1 voltage	50 100
Grid voltage, Adjusted to give suitable luminous spot	
Deflection Sensitivity:	
Plates D <sub>1</sub> and D <sub>2</sub>	0.15 0.07 Mm/Volt D.C.
Plates D <sub>3</sub> and D <sub>4</sub>	0.21 0.10 Mm/Volt D.C.

**25L6** An all metal 6L6 for AC-DC Operation

Heater Voltage	25	25
Plate Voltage	110	110
Screen Voltage	110	110
Grid Voltage	-7.5	-7.5
Zero-Signal Plate Cur.	49	49
Max-Signal Plate Cur.	55	51
Zero-Signal Screen Cur.	4	4
Max-Signal Screen Cur.	8	10.3
Signal Input Voltage	5.3	5.3
Plate Resist. (Approx.)	10,000	10,000
Transconductance	8,200	8,200
Load Resistance	1,500	2,000
Distortion:		
Total Harmonic	11	10
Second Harmonic	10	3.5
Third Harmonic	4	8.5
Power Output	2.1	2.2

## AMATEUR NOTES

**RK39** A beam power type tetrode by Raytheon similar to the 807.

Class C Amplifier Typical Operation		
DC Plate voltage	500	750 volts
DC Plate current	60	80 ma.
DC screen voltage	200	250 volts
DC screen current	10	10 ma.
DC grid bias	40	60 volts
DC grid current	4	4 ma.
Power output	23	40 watts
Plate dissipation	7	20 watts
Driving power	.2	.5 watts

**High Frequency Super** — In the new Hallicrafter 5 to 40 meter superhet, selectivity may be varied from a sharp crystal filter curve to one with a band width of a hundred K.C. The purpose of this is to permit reception of frequency modulated signals on the five meter band.

A 6K7 and 6L7 serve as first and second I. F. respectively. Special iron core I. F. transformers operating at 1600 K.C. have a third winding close coupled to the primary and connected to the secondary. This winding (L<sub>1</sub>L<sub>2</sub>) may be switched in or out of the circuit at will, increasing the coupling between primary and secondary and thereby overcoupling the two. In this manner a broad resonant curve is obtained which is sufficiently wide to pass any modulated oscillator type of signal. At the same time, however, by tapping just part of the winding, an intermediate degree of selectivity results.

With the switch in the neutral position a high degree of selectivity is available for tuning on the 40, 20 and 10 meter bands. In the first position, stable five meter signals can be copied with high selectivity between stations. Signals that are badly frequency modulated, but still understandable on a super-regenerative type receiver, can be easily received with the full winding in the circuit.

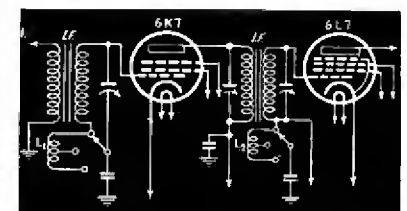

This method of selectivity control was found more suitable than the usual movable coil type, since, because of the high I. F. frequency, movement of parts near the I. F. coil tended to detune this circuit.



# Go Places in '37

WITH THESE  
AND OTHER  
MONEY-MAKING

## WESTON Instruments

Go further in '37 with WESTON instruments. Save time . . . because WESTONS simplify and expedite testing procedure. Build a satisfied clientele . . . have fewer call backs . . . because WESTONS do a thorough servicing job, and the readings are always dependable. *And save money* by not having to replace your instruments frequently. WESTONS are designed and built to serve dependably for years. Make yours a completely WESTON equipped shop in '37. It's easy to do with the WESTON INVESTMENT PLAN. Ask your jobber for details, or return coupon.



The WESTON Model 772 Analyzer. Sensitivity of 20,000 ohms per volt . . . resistance ranges readable up to 30 megohms . . . current indications as low as 1/2 microampere. Will put you years ahead of competition. Price \$46.50 net to dealers in U. S. A.

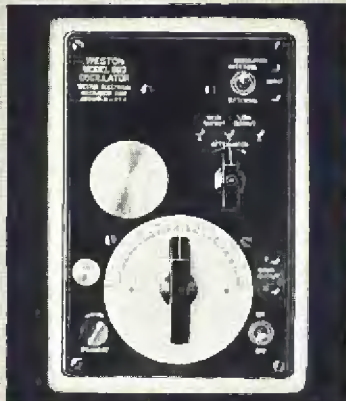

The WESTON Model 692 all wave, triple-shielded oscillator. A real laboratory job at a price servicemen can afford. Designed to do a precision aligning job on all radio receivers. Price \$45.00 net to dealers in U. S. A.



The WESTON Model 669 Vacuum Tube Voltmeter. For use with or without test oscillator . . . for measuring gain per stage . . . r.f. amplitude in oscillator circuit of superheterodynes . . . making all tests on a.v.c. currents . . . and all measurements where high frequency is a factor. Price \$45.00 net to dealers in U. S. A.



The WESTON Model 771 Checkmaster . . . a real tube checker plus continuity tester. A compact trouble-shooter for field use. Has voltage and resistance ranges for point-to-point and continuity testing. Price \$45.00 net to dealers in U. S. A.

WESTON  
ELECTRICAL  
INSTRUMENT  
CORPORATION  
581 Frelinghuysen Avenue.  
Newark, New Jersey  
Please rush me complete data on  
all WESTON Radio Instruments.

NAME \_\_\_\_\_  
ADDRESS \_\_\_\_\_  
CITY \_\_\_\_\_ STATE \_\_\_\_\_



# OSCILLOGRAPH CIRCUITS

Interest in cathode-ray instruments is running high. Here, gathered together for servicemen who wish to study the differences between various manufactured units, are seven typical circuits, including parts values where these are obtainable.

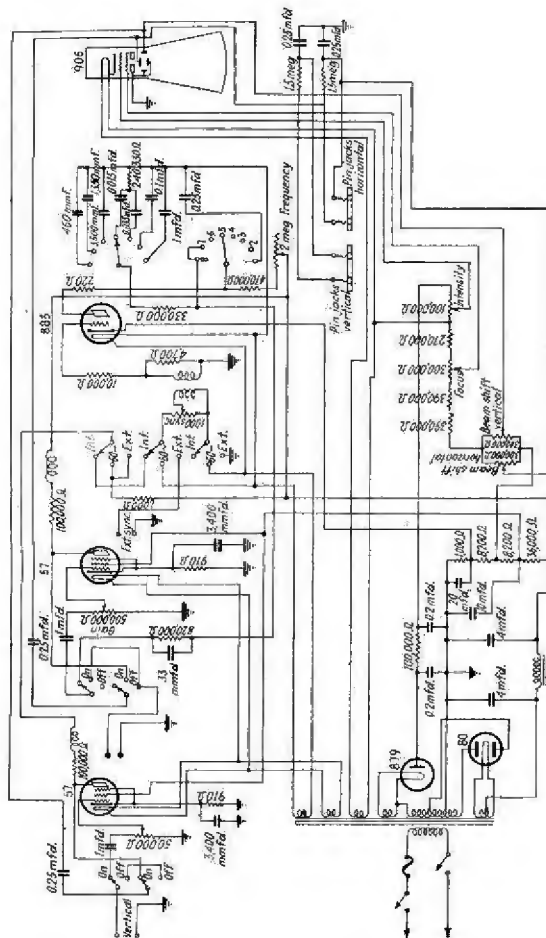

**RCA**  
Model TMV-122D

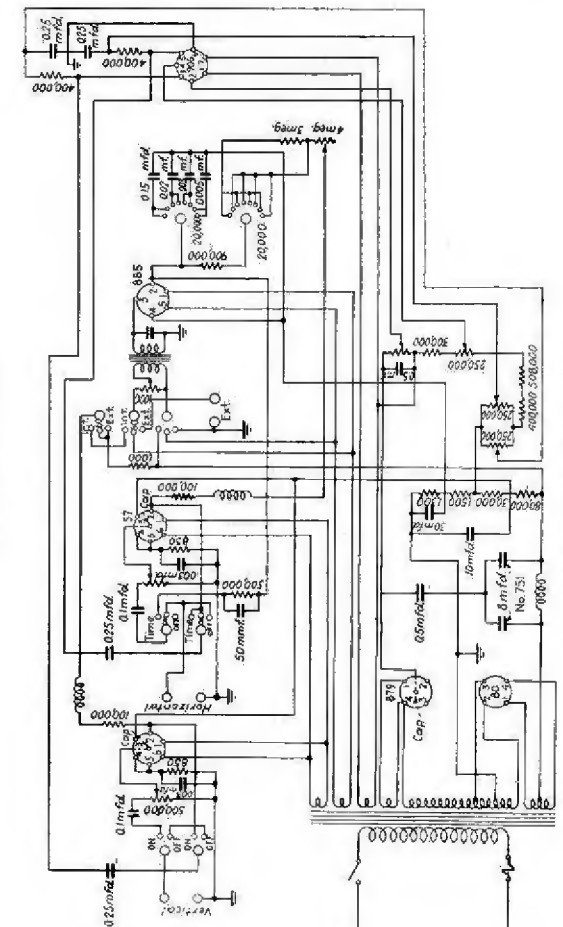

**UNITED SOUND**  
Model CR-3

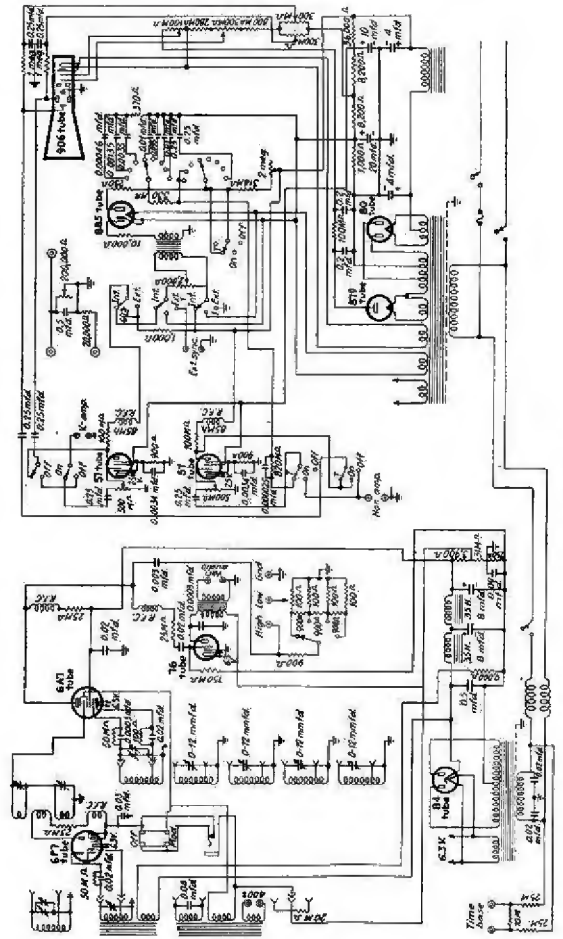

**SUPREME**  
Model 555





# A NEW SUPREME ACHIEVEMENT!

The 555 DIAGNOMOSCOPE  
Combines 4 instruments in ONE



Now you can have all the equipment necessary for modern up-to-date cathode ray service work—complete in one impressive unit! The Diagnoscope is actually four instruments in one... a complete testing laboratory in itself! [1] Cathode Ray Oscilloscope [2] Frequency Modulator [3] Audio Oscillator [4] All-Wave Signal Generator which may be used [a] Unmodulated [b] Frequency Modulated Internally [c] Amplitude Modulated Externally [d] Amplitude Modulated Internally by 400 Cycle Fixed Frequency.

Before you buy any instruments, see the 555 Diagnoscope at your parts jobber. Its many new outstanding features... its simplicity of operation... its conveniently arranged controls... and its beautifully designed streamlined case will astound you! Contains 10 tubes. Completely A. C. operated.

Your parts jobber offers you convenient time payment terms on any SUPREME instrument, making it easy for you to purchase them *now!* You don't have to wait until you are ready to pay all cash.

See your parts jobber today. Ask him to show you the Diagnoscope. He will give you full details on how you can purchase it on the S.I.C. easy payment plan.

### 500 AUTOMATIC

Combines 12 essential servicing instruments:  
A. C. Tube Quality Checker, Tube Hot Leakage, Short and Open Tester, Electrolytic Filter Capacitor Leakage Tester, Paper and Mica Capacitor Leakage Tester, Complete Point-to-Point Radio Analyzer, Multi-Range D. C. Voltmeter, Multi-range Ohmmeter, Multi-range Megohmmeter, Multi-range A. C. Voltmeter, Multi-range Decibel Meter, Multi-range Milliammeter, Multi-range Output Meter. \$7.50 Down—\$6.61 per Month for 10 Months. Cash price...\$66.95

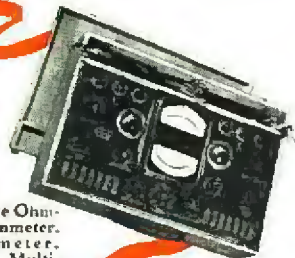

### 550 RADIO TESTER

Performs the operations of 13 essential servicing instruments with 43 functions and ranges: Radio and P. A. Analyzer, Electrolytic filter and electrostatic capacitor leakage, also Electrolytic and Electrostatic capacitor tester, Multi-range ohmmeter, Multi-range D. C. Voltmeter, Multi-range A. C. Voltmeter, Multi-range milliammeter, Multi-range decibel meter, Multi-range output meter, D. C. ammeter. \$6.00 Down—\$5.55 monthly for 10 months. Cash Price...\$55.95



\$15.00 Down  
\$12.05 per month  
for 12 months  
Cash Price \$147.95



WHERE SHOULD THE RADIO SERVICE MAN LOCATE HIS PLACE OF BUSINESS?

"This interesting booklet is the result of a nationwide survey made for your benefit. Write me today and I will mail you a copy free of charge."

*Your Parts Jobber*  
Remember—YOUR CREDIT IS GOOD WITH SUPREME!

**SUPREME INSTRUMENTS CORP.**

**GREENWOOD, MISSISSIPPI, U. S. A.**



## Testing for Leaks in Paper Condensers

By R. S. West

Perhaps the most annoying and hard-to-locate trouble encountered in radio servicing is the static-like noise caused by faulty paper condensers and carbon resistors. In condensers the bad unit may not be located by the usual tests, even though the noise may be very loud

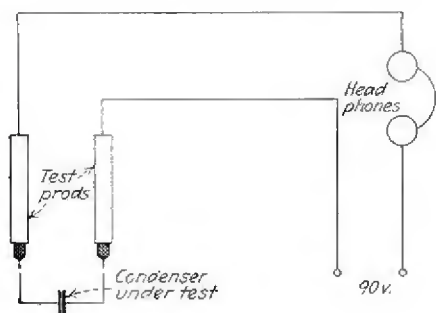

as heard in the speaker. In order to locate the faulty condensers as quickly as possible, the writer uses the arrangement shown. The head-phones will indicate leaks which cannot be found with the average condenser tester.

In actual use the condenser is not removed from the circuit; precautionary tests for a short circuit should be made, however, before making the leakage test as the 90 volts might burn out the head-phones if a "short" really exists. The test prods are held against the condenser terminals for at least two or three minutes. If the condenser is good there should be no sound in the phones other than the usual charging click; if an intermittent or steady noise or popping sound is heard, the condenser should be replaced.

## Revamping All-wave Receivers for Communications

By R. E. Snoddy

Most servicemen are interested in Amateur Communications as a hobby, and certainly every serviceman, to be up to date, should be familiar with schedules of foreign short wave stations and the various other services on the high frequency bands.

With a few simple changes, the modern All-Wave Broadcast receiver can be converted to an excellent Communications type receiver, for phone or CW (code) reception, and its sensitivity to very weak signals greatly increased.

In the past the greatest objection to the use of a standard All-Wave receiver

for amateur communication was the lack of band spread on the amateur bands. This has been well taken care of in some of the latest receivers, especially those that have a large dial and a "second" hand. The dial should have a minimum of back-lash too, if you intend to do much "fishing" for weak stations.

The changes necessary are the following: (a) The addition of a beat frequency oscillator with a switch for cutting it in or out at will. In some cases the addition of a variable sensitivity control in the R.F. circuit will be necessary to get the proper action of the beat oscillator.

(b) A switch for cutting out the AVC action for the reception of code signals.

(c) Headphone connections for distant reception and nightows.

The beat oscillator itself is very simple. The circuit shown in Fig. 1 has proven itself to be simple and unusually stable.

The parts necessary are as follows:

LC—beat note oscillator coil (Hammarlund type T)

R1—75,000 ohms. C1—.0005 mmf.

C2—Small trimmer condenser. R2—25,000 ohms.

Switch, 6C5G tube, socket and shield.

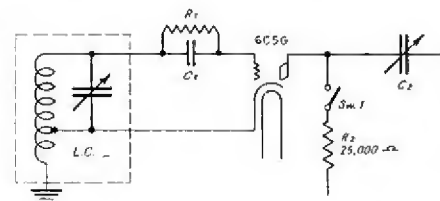

The oscillator coil has a range from 450 to 470 kilocycles. If some other intermediate frequency is used in the receiver a different beat-oscillator coil will be necessary. The cut out switch can be either in the plate circuit or the cathode circuit, whichever is most convenient.

The coupling condenser C2 may be a small trimmer condenser or a few turns of wire wrapped around the plate lead. The beat oscillator is adjusted in the following manner:

With the AVC and the beat oscillator off, tune in a very weak signal to exact resonance. Turn the oscillator on and adjust the beat-oscillator trimmer condenser until the desired note is obtained. Do this several times to make sure that the adjustment is correct.

Now with the beat oscillator on and the receiver still tuned to a weak signal, adjust the coupling condenser for the best note. If the coupling is too tight it will blot out the signal. Now tune in a strong signal. If the coupling is not tight enough, the signal may blot out the oscillator. The final adjustment will be

a compromise between the two. A better method is to leave the coupling set for the weaker signal and add a variable sensitivity control. This may be a potentiometer in the cathode lead of the RF or IF tubes or the familiar antenna-cathode volume control, depending on the particular set in which the change is being made.

The beat oscillator may be coupled to the last IF grid or to one of the diode plates. If it is coupled to the last IF grid, very little coupling will be required, the oscillator will be lightly loaded, and its stability increased. It is well to try different plate voltages on it too. Usually a low plate voltage is best, but it should not be so low, however, that the oscillator will not start every time the switch is thrown.

Now about cutting out the AVC. In some sets it is possible to short out the resistor across which the AVC voltage is developed. If this doesn't work another resistor, (R2 in the diagram) may be switched into the circuit by means of a S.P.D.T. switch. This in no way upsets the rest of the circuit. The switch may be mounted on the chassis or can be attached to the sensitivity control in place of the regular off-on switch that is usually attached to these controls. It can be connected so that in the "off" position the AVC is working and the cathode control is at zero resistance for normal operation. This will cause this control to work in the wrong direction, but this is not a serious objection, as it is not used very much anyhow.

Be careful to use only rubber covered wire in the AVC circuit as even a high resistance leak in damp weather will cause faulty AVC action. Make these leads as short as possible and inclose them in a braided metal shield. Otherwise motorboating may develop.

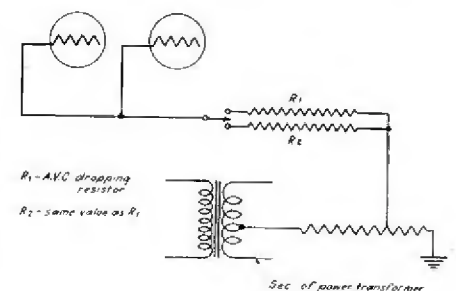

## Spray-Shield Replacements

By Marion L. Rhodes

In many old style T.R.F. receivers using a 27 detector, hum can be greatly reduced by using spray-shield tubes such as a Majestic G-27-S.

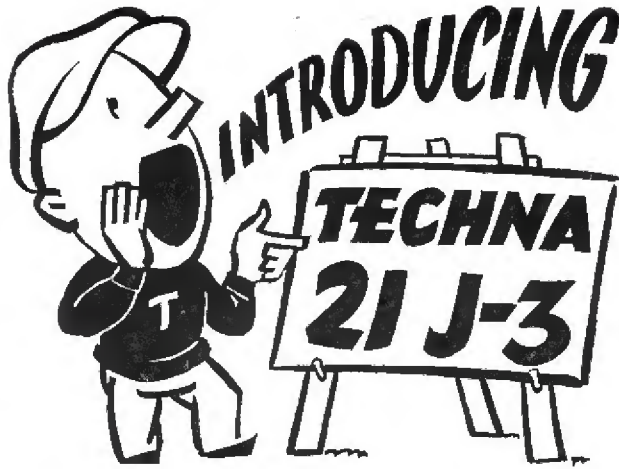

## A COMPLETE 15 WATT P. A. SYSTEM FOR PERMANENT INSTALLATION

Here is an efficient, attractive, low-cost public address system especially designed for schools, theatres, night clubs, and similar permanent installations.

The system includes the microphone, two 10-inch dynamic speakers, and a 6L6 Beam Power Amplifier, mounted in a cast aluminum case with the panel mounted at a convenient angle for operation.

Each speaker is mounted in an inclined baffle cabinet so that all high frequencies are projected to "ear level," thus permitting highest fidelity reproduction. The speaker cabinets may be finished to match existing furnishings.

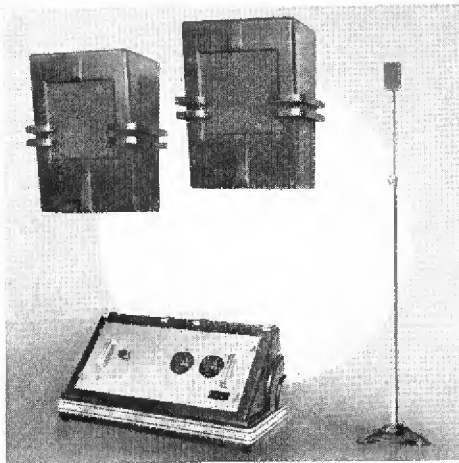

System 21 J-3, complete with all tubes, 30 feet of rubber covered and shielded microphone cable and 75 feet of cloth covered speaker cable for each speaker—\$170 list.

# TECHNA

CORPORATION  
NEW YORK · CHICAGO

926 Howard Street . . . San Francisco  
BROADCAST . . . PUBLIC ADDRESS  
RECORDING . . . LABORATORY EQUIPMENT



*"Cornell-Dubilier Sales just hit a new HIGH"*

THE WORLD'S MOST COMPLETE CONDENSER LINE  
**WET & DRY ELECTROLYTICS**  
MICA • PAPER • DYKANOL

## CORNELL DUBILIER

*It's New!*

# 2,199

PRE-TESTED IDEAS!

## RADIO BUSINESS

*Promotion and Management*

by A. A. Ghirardi and T. S. Ruggles

Here at last is the book every radio dealer and service man has been waiting for! A practical, sales-minded book that gives you the complete story on how to get more and better business. How to start a radio business. How to run one profitably. How to get and hold customers through selling, advertising, merchandising and publicity. IDEAS—FACTS—METHODS that have been *proved sound and successful* in building up businesses just like yours . . . presented and illustrated in such a way that you can put them to work right away. Everything in it is practical and workable. Applies to sale of radio sets, servicing, auto radio, P.A. work, home appliances, etc. You can't help but make more money with this great book! SEND FOR YOUR FREE CIRCULAR TODAY!

**SELLING**—Analysis of your market. Getting leads. Store selling. Phone selling. Outside selling. Sales talks. Resistances. Contacts. Etc., etc.

**ADVERTISING**—Planning. Preparation. Tested appeals. Production. Ideas for Displays. Direct Mail. Newspaper, Broadcast and other advertising media. Publicity. Merchandising. Premiums. Follow-ups. Etc., etc.

**BUSINESS METHODS**—Getting started. Shop equipment. Store layout. Management. Cost accounting. Records. Policies. Etc., etc.

Over 400 pages  
Over 200 illus.  
Soon to be released.

**CLIP and MAIL Today**

Radio & Technical Publ. Co.  
45 Astor Pl., New York Dept. RR-126

Please send me free circular BB.

Name .....

Address .....

Free Circular



## Motor Noise Detector

By B. B. Porter

A small copper disc about the size of a silver dollar, attached to the end of a wooden handle several feet long, with a shielded wire running from the disc to the other end of the handle, makes an excellent exploration tool for locating noise sources in a car when ironing out an auto-radio installation.

Connect the inner conductor of the shielded cable to the antenna post of the receiver within the driver's compartment and ground the shield to the chassis by means of a clip. Then move the disc near various points under the hood and around the body where different r.f. potentials might set up radiation of noise.

## Knee-Action Static Elimination

By M. C. Goldberg

An unusual front wheel static condition is sometimes encountered in cars having knee-action. Even though spring static eliminators were installed the trouble still persisted.

A well lubricated knee-action assembly is insulated from the chassis by a film of grease. A permanent cure for

this condition can be obtained by bolting a  $\frac{1}{2}$  inch piece of braid between the front axle or the frame at one end, to the knee-action mechanism at the other. About 30 inches is required so that it doesn't interfere with the turning of the wheels. Of course the static eliminators are still required.

## Pepping Up Old Receivers

By Harry D. Hooton

There are a great number of the older receivers of both the t.r.f. and superheterodyne types that can be given almost as much gain and selectivity as many later model sets by simply adding the small iron-cores to their r-f and i-f tuned circuits. These small cylindrical shaped cores are available and the cost is only about ten cents each.

The process is not quite so simple as merely adding the iron cores to the coils—the addition of the cylinders will cause the inductance of the coils to increase. The removal of a portion of the winding is usually necessary and the exact amount is best determined by placing the core in the i-f or r-f coil, fastening it securely in place, and then removing one or two turns at a time until the circuit is returned to its original adjustment. Each coil should be completed and adjusted to its previous setting before going on to the next.

In some receivers the addition of the metal cores will boost the gain until the circuits may oscillate. The writer has found it necessary to use a 0.1 mfd. paper condenser from the "B" plus to the chassis in most cases to eliminate oscillations. A separate condenser is used for each transformer or coil and is mounted as close as possible to the point where the "B" lead comes through the chassis.

Sometimes the addition of the cylinders will cause oscillations that cannot be eliminated by by-passing as outlined above. An examination of the circuit will usually reveal that a common bias resistor is being used for two or more of the tubes in the r-f circuit or that two or more tubes have common screen dropping resistors. In this case it is necessary to use a separate resistor for each circuit and by-pass it with the proper size paper condenser.

## Soldering Iron Holder

By Marion L. Rhodes

A good soldering iron holder can be made from a piece of asbestos pipe covering such as is used on steam pipes. A section about a foot long supported under the edge of the bench will keep the iron where it can do no damage.

"ELECTRAD CONTROLS  
Make Any Replacement  
A CINCH.....!"



## Says Mac—the Service Man

Electrad spends many thousands of dollars every year on engineering research—just to build a line of controls *mechanically and electrically right* for any receiver model.

The result is that any service man who uses Electrad Controls can truthfully say—"Electrad Controls make any replacement a cinch." . . .

Try an Electrad Control on your next replacement job. Long aluminum shafts are easily cut to required length, standard end covers are instantly interchangeable with power switch assembly. Every Electrad Control is noise tested at the factory and fully guaranteed.

An Electrad replacement is a quick, accurate, *lastingly* satisfactory job—and Electrad's clean dealer policy assures a good profit every time. Send for new 1937 Guide—150 pages of valuable replacement data that every service department needs. Address Dept. RR 12.

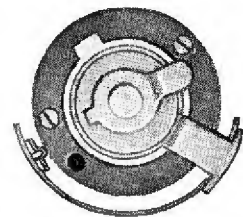

Direct friction contact . . . self-cleaning, self-polishing . . . assures quiet stepless graduation. . . . no noise, no gaps, no stuttering.



"RESISTOR HEADQUARTERS"

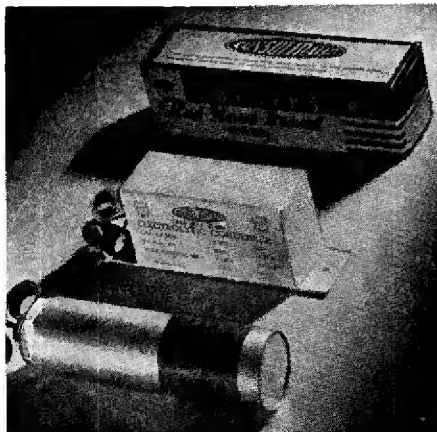

## RED HEAD BRAND CAPACITORS

RED HEAD BRAND Condensers are available in all standard sizes and capacities—in both high and low voltages. Small, compact and rugged in construction. They conform to the exacting demands of the Radio industry—in uniformity, dependability and accuracy.

High-Low Voltage  
Dry Electrolytics  
All Types

Wax Carton Units  
Single-Multiple  
Tubular Units  
Transmitting  
Tubular By-Pass  
Replacements

### DEPENDABLE

A consistently maintained policy makes "RED HEADS" ideal for "over the counter" sales. Attractively packaged for effective display.

The manufacturing trade will appreciate the practical solution they offer to the condenser problem. Write for prices.

**CONSOLIDATED**  
WIRE AND  
ASSOCIATED  
**CORPORATIONS**

512 So. Peoria St. • Chicago

# LET NATIONAL UNION EQUIP YOU FOR 1937's SERVICE PROFITS!

The well equipped Radio Service Expert will cash in most on 1937's business

### TIME PAYMENTS ON DEPOSITS

N. U. has made arrangements with Clough-Brengle and the Supreme Instruments Corporation so that the initial deposit on the new 1937 models made by these great equipment manufacturers can be financed. Remember, initial deposits are refunded when tube purchases are completed. Get complete details from your distributor.

### INSTRUMENTS MADE BY THESE MANUFACTURERS

Study the catalogs and advertisements of leading service equipment manufacturers listed below, select the instruments you want . . . then find out how you can get them FREE the easy National Union way!

Clough-Brengle • Supreme Instruments Corporation • Triplett Ranger • Hickok • Webster-Chicago • J. F. D. • Precision Communication Instruments Inc. • Radio City Products • Allen B. DuMont Labs.

In addition to instruments, you can get Shop Coats, Radio Tube Carrying Cases, Multi Drawer Steel Cabinets for small parts storage, etc. Be sure to find out how!

### FREE EQUIPMENT!!

No need for the alert and aggressive service expert to read about all the fine scientific instruments which service equipment manufacturers are making and wish that he might own them. Why? He can own them! How? By getting them Free with the purchase of National Union radio tubes.

This means that you and every other service specialist who hopes to capture a big share of the profit to be made in the service business in 1937 can equip yourselves with the meters, testers and analyzers so necessary in modern radio servicing.

National Union has given servicemen throughout the United States more than 50,000 pieces of fine equipment. If you're not taking advantage of National Union's service dealer plan, you're missing the greatest opportunity in the radio industry today.

All you do is contract to purchase a few tubes per week, place a small deposit, which is refunded to you after the tube purchase is completed and the instrument you have selected is yours "for keeps", without any strings attached. Meanwhile, remember that you have the use of the instrument all during the time tube purchases are being made.

Make 1937 your biggest profit year by tying up with the National Union Selling Program. Talk it over with your distributor or send the coupon below for complete details.

### ABOUT NATIONAL UNION RADIO TUBES

National Union manufactures a complete line of radio tubes in glass, metal and G-type. National Union's high quality has made them the outstanding favorite in the radio service profession. All sales policies have been formulated with the idea of making National Union radio tubes the ideal replacement tube for the radio dealer. This has been backed up with a selling program that means real support and help to the wide-awake dealer. Dealers and jobbers handling National Union radio tubes are the leaders in repair parts and service.

Clip - Mail - Now!



National Union Radio Corp., RR 1236  
570 Lexington Ave., New York City.

Rush free circular telling how to get instruments the easy N.U. way.

Name .....  
Street .....  
City ..... State .....

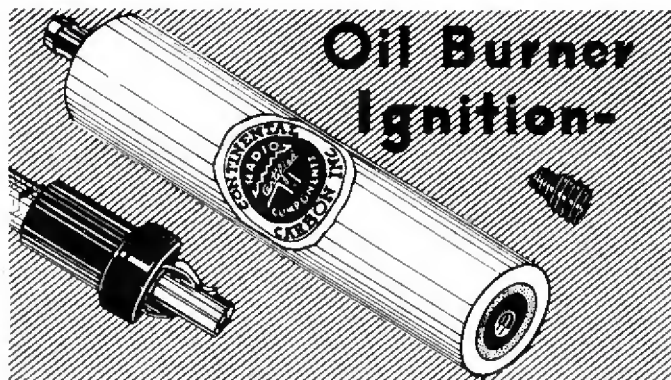

### Interference Suppressor!

Extra profit from your customers with oil burners that interfere with their radios! You can make extra money on many of your service calls. Every oil burner ignition system, which interferes with radio, needs two CONTINENTAL Carbon OB15 Filternoys suppressors. These suppressors connect in series with the high-tension leads of the ignition transformer. If the electric wiring is well shielded, CONTINENTAL OB15 Filternoys suppressors completely eliminate radio interference from the ignition system.

Filternoys suppressor OB15 has a list price of \$1.50. Carry a couple on your holiday service calls. They will bring you \$1.20 profit on every sale!

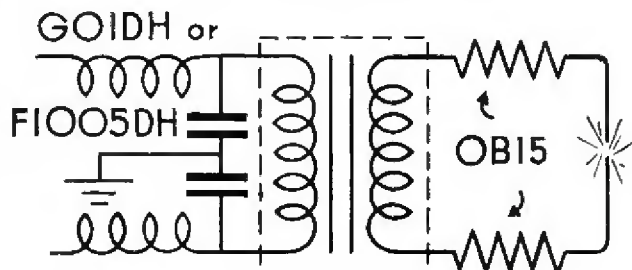

Oil burner systems sometimes require extra filtering on the primary side of the ignition transformer. CONTINENTAL Carbon Filternoys suppressor GO1DH, list price \$1.50, is particularly suitable for circuits up to 300 watts, 120 volts. Use F1005DH, list \$5.00 on equipment up to 800 watts, 120 volts.

Be the first in your community to guarantee full relief from oil burner interference.

Send for your copy of Handy Pocket Data on Radio Interference Elimination containing the latest information on this important subject. It is written so that you may show it to your customers; it is your silent salesman for CONTINENTAL Carbon Filternoys interference suppressors.

**CONTINENTAL CARBON Inc.**

13902 Lorain Avenue, Cleveland, Ohio

Toronto, Canada



# ACTUAL SOCKET VOLTAGES

(Measured to chassis with 1000-ohms-per volt D. C. instrument)

**38**  
Audio

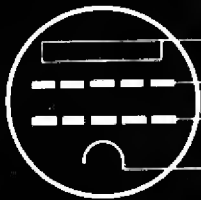

A.C.	A.C.-D.C.
145 to 170	105 to 115
150 to 185	95 to 105
0	0
11 to 14.5	9 to 11

**6J7**  
Detector

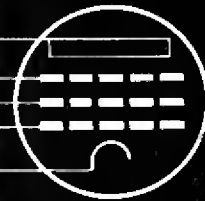

A.C.	AC-D.C.
0 to 1	0 to 1
2.6 to 4	2 to 3
65 to 15	65 to 85
0	0
2.6 to 4	2 to 3.5

**77**  
Mixer

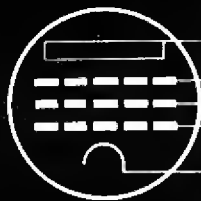

A.C.	A.C.-D.C.
240 to 277	80 to 115
0 to 7	0
100 to 110	105 to 115
0	0
7 to 20	17.5 to 22

**6K7**  
R. F.  
Amplifier

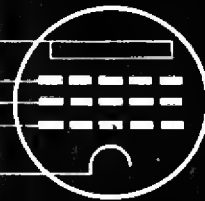

A.C.	AC-D.C.
232 to 265	99 to 110
0 to 2.5	0 to 3
90 to 110	105 to 115
0	0
0 to 3.5	0 to 3

**78**  
R. F.  
Amplifier



A.C.	A.C.-D.C.
245 to 275	105 to 120
0	2 to 2.5
160 to 170	85 to 95
0	0
0 to 3.1	2 to 2.5

**25A6**  
Audio

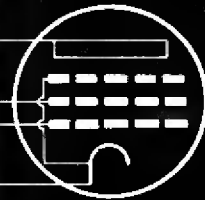

A.C.	AC-D.C.
Not used	93 to 102
	102 to 111
	0 to -0.6
	10 to 12.5

**6B5**  
Audio

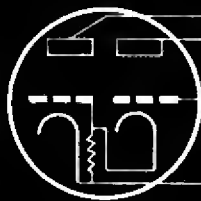

A.C.	A.C.-D.C.
225 to 285	90 to 105
215 to 265	90 to 105
0	0
0 to 4	0 to 2

**25B5**  
Audio



A.C.	AC-D.C.
Not used	105 to 115
	90 to 115
	0
	0

**6C6**  
Detector



A.C.	A.C.-D.C.
35 to 40	18 to 22
0	0.1 to 0.5
20 to 26	12 to 15
0	0
3 to 5	17.5 to 22

**6E5**  
Tuning  
Indicator



A.C.	AC-D.C.
240 to 265	105 to 118
0	0
0	0
-1 to -2.5	-1 to -2

**6D6**  
R. F.  
Amplifier

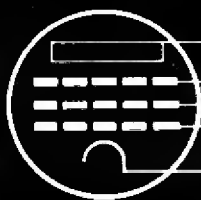

A.C.	A.C.-D.C.
240 to 265	105 to 118
4 to 7	2.5 to 3.5
80 to 110	90 to 118
0	0
2.5 to 7	2 to 5

**6G5**  
Tuning  
Indicator



A.C.	AC-D.C.
245 to 265	105 to 118
0	0
0	0
-1 to 3	-1 to 2.8

This is the last of a series of Actual Socket Voltage Charts covering typical uses

**RADIO  
RETAILING**

of most commonly encountered tubes. Two others appeared in October and November.



MODEL  
2L-20

Greater

**FLEXIBILITY**

IN THIS 20-WATT AMPLIFIER

- ★ NEW 2 POSITION INPUT
- ★ IMPROVED TAPPED OUTPUT COMBINATION
- ★ USES BEAM TYPE TUBES

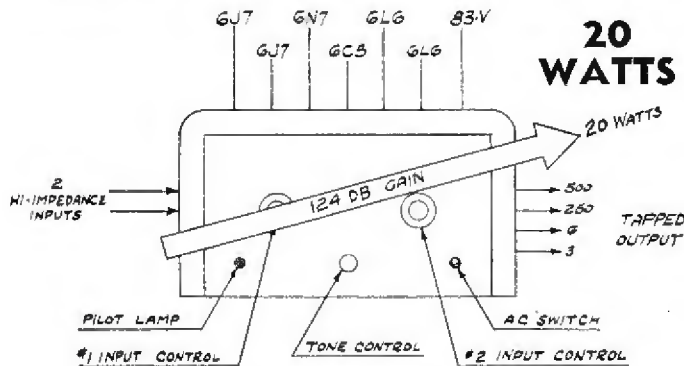

This beautiful new sound amplifier, Model 2L-20 has just been announced by Webster-Chicago. It definitely sets a new standard of power output for size and weight and creates a new order of flexibility. Thoroughly portable, attractively priced.

The input arrangement will handle two microphones either of the crystal, high impedance velocity or new velotron type; or 1 microphone and 1 phonograph input; or 2 phonograph inputs

The output impedance is tapped at 3-6-250-500 ohms giving extremely flexible speaker combinations with speakers such as Webster-Chicago models 2871, 2861 and 2851. Using the 250 ohm tap eight of any type of above speakers can be properly matched.

Webster-Chicago are old established manufacturers of P. A. Systems, Sound Equipment and Accessories of all kinds; a full line of carefully engineered merchandise, priced right. The sound line that all dealers should handle.

TIME PAYMENT PLAN

FULLY LICENSED

STRICT DEALER POLICY

**WEBSTER - CHICAGO**

Webster-Chicago  
Section D-8, 3825 W. Lake St., Chicago, Ill.

Please send me more information on Amplifier 2L-20 . . . I am also interested in . . .

Name . . . . .  
Address . . . . .  
City . . . . . State . . . . .

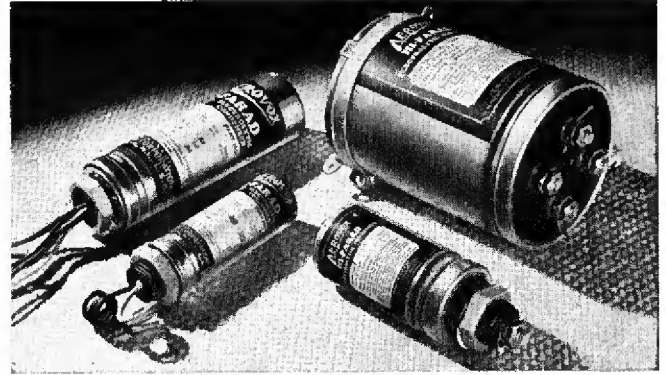

**METAL-CAN Electrolytics**



Type E: Vertical mounting. Grounded can. Single, dual, triple sections.



Type I: Inverted. Insulated mounting.



Type GL: Inverted. Insulated mounting. Single, dual, triple. Individual leads.



Type GLS: Mid-get units. Inverted. Insulated mounting. 1" dia. Half height of usual units.

**T**HE most capacity in least bulk . . . lowest cost . . . longest trouble-proof service. That's the story of AEROVOX metal-can electrolytics. Also, the greatest variety of electrolytics to meet every requirement.

**New CATALOG**

More pages.  
More items.  
More choice.

Popular prices. Ask your local AEROVOX jobber for copy, or write us direct.



**TO DEALERS AND SERVICEMEN**

**TRIAD RADIO TUBE  
FREE!**

**UP TO \$1.25 LIST**

**A DARING NEW PLAN**

To convince you of the superior quality of Triad Radio Tubes—we are offering absolutely free any Triad Tubes up to \$1.25 list with your purchase of Triad Radio Tubes—also free Engineering Data Chart. Mail coupon below—back will come your Free Tube Certificate. Present it to your jobber when you purchase Triad Tubes and get your Free Tube—save \$1.25.

**MAIL TODAY!**

**TRIAD MANUFACTURING CO., Inc. THIS COUPON**  
Dept. M-10 Pawtucket, R. I. **WORTH \$1.25**

Sure I'll try Triads. Send me Free Tube Certificate . . . good for \$1.25. Also FREE Engineering Data Chart.

Name \_\_\_\_\_

Address \_\_\_\_\_

Town \_\_\_\_\_ State \_\_\_\_\_

Jobber's Name \_\_\_\_\_

**"THE QUALITY NAME IN RADIO TUBES"**



HERE IS *Your* CHANCE

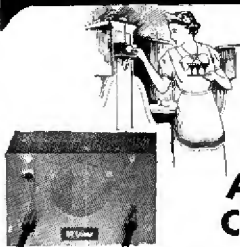

TO CASH IN ON A BUSINESS ESSENTIAL

**BELphone**  
A COMPLETE TWO-WAY COMMUNICATING SYSTEM

for \$39.50

The market is unlimited. Every business needs the economy — the convenience — of the new BELphone method of communicating between departments. You merely flip a key on a little unit (the size of midget radio) and have clear and distinct conversation with other departments. Arranged for two stations or multiple stations for desk-to-desk use, — or FOR CONVERSING WITH A PERSON FROM ANY POINT HE MAY BE IN A LARGE ROOM — BELphone saves time, steps and effort. BELphone actually sells itself on demonstration. It's as easy to install as a buzzer system and works on your regular current . . . economical in every respect! Convince yourself on this new money-maker by installing a BELphone for your own use.

Slightly higher west of the Rockies.

Write TODAY for the facts on BELphone. Only BELphone gives you quality construction necessary for permanent customer satisfaction.

Mr. Jobber: Here's a product worthy of your investigation.

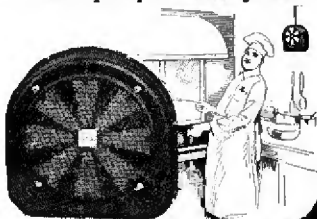

Export Office: 308 West Washington Street., Chicago, Ill.

**BELL** Sound Systems, Inc. **BEL SOUND SYSTEMS**  
62-65 East Goodale St.  
Columbus, Ohio

# RIDER'S VOLUME VII

NOW AVAILABLE AT ALL GOOD JOBBERS

PRACTICALLY EVERY MAJOR IMPROVEMENT IN VIBRATOR DESIGN HAS ORIGINATED IN THE UTAH FACTORY!

Utah has always been the leader in the design and manufacture of vibrators for radio purposes. This organization has pioneered in vibrator design, and is the recognized and leading source of the radio industry for this part.

Every Utah Vibrator embodies the same high qualities of workmanship and design found in other Utah products.

Speakers • Transformers  
Chokes • Volume Controls  
Tone Controls • Resistors  
Plugs • Jacks • Push Button Switches



Utah Vibrators are protected by one or more of the following patents:  
1924082, 1935568,  
1935569, 1944487,  
1946563, 1951614,  
1981053, 2009425.  
Other patents pending.

**Utah**  
VIBRATORS

**UTAH RADIO PRODUCTS CO.**  
CHICAGO, U. S. A.

TORONTO  
ONTARIO CANADA

BUENOS AIRES  
(UCOA RADIO PRODUCTS CO.)

"15 YEARS OF LEADERSHIP"

# INDEX TO ADVERTISERS

DECEMBER, 1936

	Page		Page		Page
AEROVOX CORP. ....	65	HYGRADE SYLVANIA CORP. ....	45	STROMBERG-CARLSON TELE. MFG. CO. ....	2
(Condensers)		(Radio Tubes)		{Radio Sets}	
ARCTURUS RADIO TUBE CO. ....	51	INTERNATIONAL RADIO CORP. ....	17	SUPREME INSTR. CORP. ....	60
(Radio Tubes)		(Radio Sets)		(Radio Test Equipment)	
BELL SOUND SYSTEMS, INC. ....	67	JANETTE MFG. CO. ....	39	TECHNA CORP. ....	62
(P. A. Equipment)		(Rotary Converters)		(Public Address Systems)	
BENDIX PROD. CORP. ....	39	KATO ENG. CO. ....	70	TRANSDUCER CORP. ....	69
(Testing Equip.)		(Electric Plant)		(Microphones)	
BOND ELECTRIC CORP. ....	24	KELVINATOR CORPORATION. ....	26	TRIAD MFG. CO. ....	65
(Flashlights & Batteries)		(Refrigerators)		(Radio Tubes)	
BURTON-ROGERS CO. ....	46	LEONARD REFRIGERATOR CO. ....	23	TRIPLETT ELEC'L INSTR. CO. ....	52
(Set and Tube Analyzer)		(Refrigerators)		(Elect. Instruments)	
CLAROSTAT MFG. CO. ....	70	LIFE TIME CORP. ....	39	TUNGSOL RADIO TUBES, INC. ....	40
(Volume Control)		(Sound Equipment)		(Radio Tubes)	
CONSOLIDATED WIRE CORP. ....	63	MALLORY & CO., INC., P. R. ....	Inside Front Cover	UNIVERSAL MICROPHONE CO. ....	40
(Condensers)		(Volume Control)		(Recording Equipment)	
CONTINENTAL CARBON CO., INC. ....	64	MUELLER ELECTRIC CO. ....	44	UTAH RADIO PRODUCTS, INC. ....	67
(Filters)		(Wire Clips)		(Transformers)	
CORNELL DUBILIER CORP. ....	62	NATIONAL UNION RADIO CORP. ....	64	WARD PRODUCTS CO. ....	39
(Condensers)		(Service Instruments)		(Auto Antennas)	
CORNISH WIRE CO. ....	39	NORGE DIVISION, BORG WARNER. ....	19	WEBSTER-CHICAGO ....	66
(Antennas)		(Refrigerators)		(Sound Equipment)	
CROSLY RADIO CORP. ....	Inside Back Cover	PIERCE-AIRO, INC. ....	38	WESTINGHOUSE ELEC. & MFG. CO. ....	30
(Radio Sets)		(Radio Sets)		(Refrigerators)	
DISTRIBUTOR'S SALESMAN ....	50	RADIO & TECH. PUBL. CO. ....	62	WESTON ELEC'L INSTRU. CORP. ....	57
(Publication)		(Service Manuals)		(Instruments)	
DUMONT ELECTRIC CO., INC. ....	46	RADIO CORP. OF AMERICA. ....	36, 37		
(Condensers)		(Sound Engineering)			
ELECTRAD, INC. ....	63	R C A MFG. CO. ....	Front Cover		
(Volume Controls)		(Radio Sets)			
ELECTRICAL PRODUCTS CO. ....	40	READRITE METER WORKS. ....	54		
(Battery Eliminators)		(Tube Testers)			
EMERSON RADIO & PHONO. CORP. ....	6	RECORDING EQUIPMENT MFG. CO. ....	40		
(Radio Sets)		(Sound Equipment)			
FOX SOUND EQUIP. CO. ....	70	RIDER, JOHN F. ....	67		
(Sound Equip.)		(Service Manuals)			
GENERAL ELECTRIC CO. ....	Back Cover	SIMPLEX RADIO CORP. ....	3		
(Radio Sets)		(Radio Sets)			
GENERAL INDUSTRIES CORP. ....	70	SOLAR MFG. CO. ....	70		
(Phonograph Motors)		(Condensers)			
GREBE MFG. CO. ....	44	STEWART-WARNER CORPORATION. ....	4		
(Radio Sets)		(Refrigerators)			
HORTON MFG. CO. ....	44				
(Washers & Ironers)					

## SEARCHLIGHT SECTION

### Classified Advertising

Classification	Page
CATALOGS .....	71
EMPLOYMENT .....	71
RADIO STOCKS	
Allied Radio Corp. ....	71
Burnstein-Applebee Co. ....	71
McGraw-Hill Book Co., Inc. ....	71
Radolek Co. ....	71
Service Men's Radio Supply Co. ....	71
Williams Philco, Inc. ....	71

McGraw-Hill Publishing Company, Inc. Publication Office: 99-129 North Broadway, Albany, N. Y. Editorial and Executive Offices: 330 West 42d Street, New York, N. Y. Branch Offices: 520 North Michigan Avenue, Chicago; 883 Mission Street, San Francisco; Aldwych House, Aldwych, London, W. C. 2; Washington; Philadelphia; Cleveland; Detroit; St. Louis; Boston; Atlanta, Ga.



## TRICKS OF THE TRADE

### AIRLINE 62-70, 62-72

Intermittent fading . . . Replace .04 coupling condenser between 56 detector and 47.

### ARVIN 617

Crackling, flickering pilot lights . . . no ground between dial frame and set chassis. Run short flexible lead between two and solder well.

### CROSLEY 167

Oscillation all over dial when volume is turned on full, noise like fog-horn with control at minimum . . . Look for open or lowered value electrolytic filter block on underside of chassis directly beneath power transformer. To locate defective unit shunt 8 mike, high voltage test unit across one at a time.

### DELCO R-1119

Repeated blowing of line fuse during warm up period . . . Replace 3 mfd. 250 volt electrolytic condenser with 400 volt unit.

### GE K62, RCA R11

Motorboating . . . Connect a .1 across the resistor mounted inside the antenna coil.

### GRUNOW 6C, 60

Distortion . . . a.f. coupling condenser leaky. As a matter of routine it is advisable to replace this condenser regardless of complaint.

### KELLOGG 523, 526

Hum . . . Connect a .02 600 volt condenser from high voltage contact on 80 tube socket to ground. Try both contacts as one is more effective than the other.

### MAJESTIC 70, 71

Weak, intermittent . . . Look for a fungus growth or mould on fabric insulation of R.F. wiring, no rubber under fabric of wire. Rewire with rubber and varnished cambric insulated wire.

### MAJESTIC 460A

Motorboating and no reception . . . High resistance connection between grid lead of 58 I.F. and lug on I.F. transformer.

### MOTOROLA '35-'36

Jumps station on bumpy road . . . loose drive gear. Take out chassis reset drive gear and tighten.

### MOTOROLA 60

Volume cutting in and out . . . speaker field wires loose. These joints appear to be welded instead of soldered.

### MOTOROLA 75

Intermittent . . . .01 coupling condenser (marked 1518) between 75 plate and 4I grid shorting, replace.

### PACIFIC 25

Erratic band change action, microphonic, intermittent . . . Rotor of band change switch riding on outside of stator members rather than on top. Remove rotor retainer horseshoe and slip rotor back an inch; any stator members not showing wiper tracks should be bent outward.

### PHILCO 30

Dead, no screen voltage . . . Common cause is shorting of .25 condenser connected from choke to chassis. This is one section of a dual unit in a metal can near the choke terminals.

### PHILCO 38

Oscillator dead . . . Remove oscillator coil and heat thoroughly to drive out moisture. Dip in a 50/50 preparation of beeswax and paraffin, when cool replace.

### PHILCO 37-610

No short wave reception . . . small mica condenser (part No. 20) soldered to tuning condenser worked loose. Resolder and bend to clear plates of variable condenser.

### PHILCO 60

Intermittent or low volume . . . Check for high resistance open in secondary of antenna coil.

### RCA 121 (GE K-64)

Motorboating . . . If fingertip on control grid of rearmost 58 stops oscillation, remove red lead coming from C-28 in 3 section electrolytic pack and replace with single 8 mfd. unit.

## THE "BULLET" DYNAMIC MICROPHONE

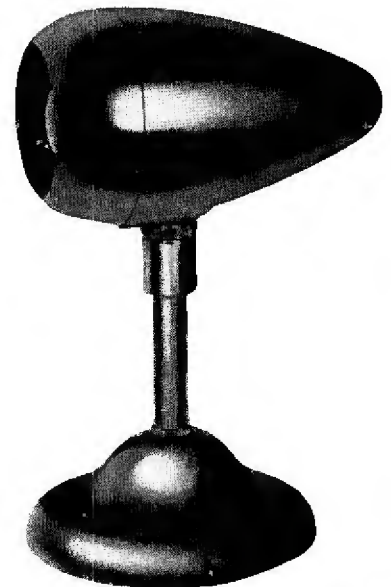

### AT LAST an ALL-PURPOSE Microphone . . .

With a sensitivity that provides sufficient power to permit almost unlimited lines . . . Different impedances to match any amplifier having from five to five hundred thousand ohms input impedance . . . A perfect microphone for indoors yet rugged enough to meet every outdoor purpose . . . Tone quality equal to much higher priced instruments of similar type.

Consider these SEVEN outstanding "BULLET" features combined in one microphone . . .

- Maximum sensitivity
- Effective at long distance from amplifier
- Wide choice of impedances
- Attractive, modern appearance
- Unequaled for severe outdoor work
- Remarkable tone quality

● Moderately priced

*A few territories are still open for exclusive distribution*

**TRANSDUCER CORPORATION**

**30 Rockefeller Plaza  
New York, New York**

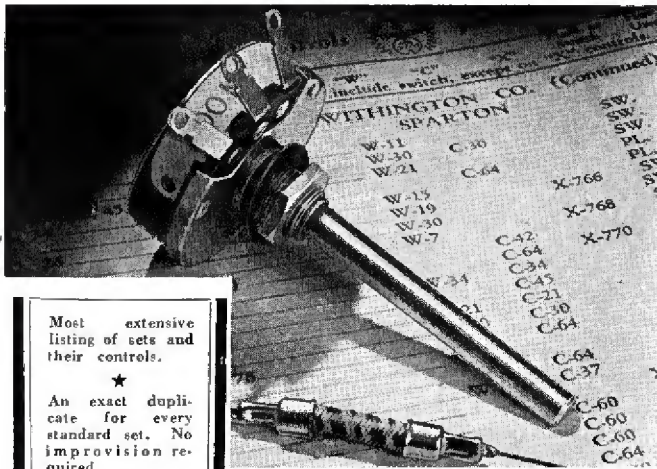

Most extensive listing of sets and their controls.

★ An exact duplicate for every standard set. No improvisation required.

★ Any resistance, taper, taps and shaft.

★ External resistor for required bias.

★ Ad-A-Switch snaps on rear of case.

★ Smooth, noiseless dependable, long-lived. And they cost no more than others.

## Exact-Duplicate CONTROLS

For repairs that must be right mechanically, electrically, visually. These controls, precisely matching the initial equipment, save time, trouble, money. They build your reputation and good will.

**Free MANUAL** Big 80-page Replacement Guide is yours for the asking. See your local jobber, or write us direct for your copy.

**CLAROSTAT** Manufacturing Co. Inc.  
 285-287 NORTH SIXTH STREET  
 BROOKLYN, NEW YORK, U.S.A.  
 • OFFICES IN PRINCIPAL CITIES •

## Play **SAFE** with



... in standard cartons of 10 **MOLDED IN BAKELITE**

● A modern high quality paper condenser completely encased in protective bakelite . . . superior in appearance and performance to ordinary paper tubulars. DOMINOES are small, flat, easy to use; resist heat and moisture; offer permanent capacity and full voltage protection. **COMPARE!**

Wide range of capacities up to .25 mfd. 200 volts, .1 mfd. 400 volts, .05 mfd. 600 volts.



**SOLAR MFG. CORP.**

599-601 Broadway, New York City

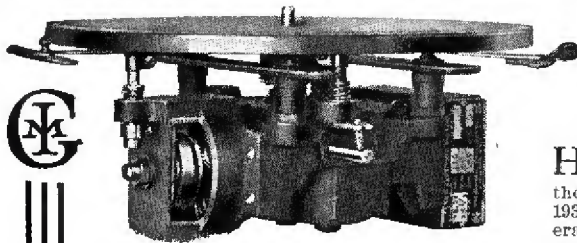

### FLYER 2-SPEED MOTOR

Order samples to test and be sure to specify exact voltage and frequency for current you use.

**The GENERAL INDUSTRIES CO.**

3637 TAYLOR ST., ELYRIA, OHIO

## What Is Under the Hood Goes for Phonographs, Too

**H**ANDSOME cabinet styles, changed season by season, imply—in fact, make imperative—that the mechanism they conceal is likewise the most modern, improved, efficient. Insure this absolutely for your 1937 phonographs and radio-phonographs, by installing the latest General Industries FLYER Motors. Insure smooth, steady, unwavering operation, independent of record drag and pick-up weight. Insure noiselessness, no disturbing motor whir or hum. Insure long, trouble-free service.

For over thirty years General Industries has specialized in precision-built phonograph motors, producing millions that have sold and given such service. The latest governor-controlled, induction type Two-Speed Flyer embodies every improvement all those years have taught. Plays both 33 1/2 and 78 r.p.m. records, adjusting speed instantly by simple lever control. Its laminated bakelite gears, running in oil, completely self-enclosed, operate silently, steadily. Long over-size bearings defeat wear. Precision-built, precision assembled, AC-DC or universal AC-DC types for all commercial voltages and frequencies.

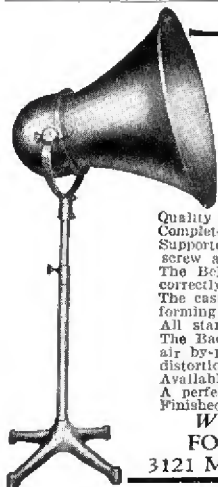

## OUTSTANDING! The New Fox B-5 Universal Baffle Type Horn

Quality construction. Completely universal in directional characteristics. Supported by a sturdy adjustable cradle complete with lock screw adjustment. The Bell is made of FOX special alloy horn material and is correctly designed for utmost output. The cast aluminum throat collar reinforces the entire assembly, forming a perfect foundation for speaker mounting and cradle. All standard 12-inch speakers can be used. The Back Cover is of heavy horn material and has the proper air by-pass so that the speaker can breathe, thus eliminating distortion. Available complete with adjustable stand. A perfect combination for indoor or outdoor work. Finished in standard aluminum gloss or Fox special wrinkle.

Write for catalog sheets and prices.  
**FOX SOUND EQUIPMENT CORP.**

3121 Monroe Street Toledo, Ohio

## 110 VOLTS AC ANYWHERE

With Katolight Jr. Complete light plant for \$49.95. Electricity at price anyone can afford. Dealers you can sell the Katolight Jr. Each plant sold creates lifetime user for lamps, motors, wiring, Radio and appliances.

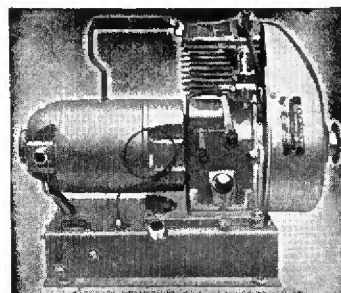

6 V. 150 watt.....	\$49.95
12 V. 200 watt.....	59.95
32 V. 300 watt.....	72.00
110 V. 300 watt A. C.	87.50
110 V. 350 watt, A. C.	
Self-cranking .....	98.00

Ask about 450, 550, 750 and 1000 watt complete plants made by mfs. of AC & DC Plants, Diesel Plants, Generators, Rotary Converters.

**Kato Engineering Co.**  
 Mankato, Minn., U. S. A.



# SEARCHLIGHT SECTION

## NOW-how to repair and re-wind all types of motors . . . ELECTRIC MOTOR REPAIR LIBRARY

4 volumes, \$10.00, payable in easy monthly installments

THIS set of books should be on the shelf of every man who ever has to touch a motor for purposes of repairing it or changing it to meet different operating conditions. In shop language and with practical shop methods it covers every step in stripping, rewinding and connecting a.c. and d.c. motors of all kinds.

### How to change motors for different operating conditions

Here is all the information you need in order to determine what changes various types of motors permit; to lay out new windings for specified service conditions; and to handle every step in the work with satisfactory results.

Covers all types of motors, from those used in small household and commercial appliances of all kinds, to mining and railway motors. Explains principles underlying the different types of windings; gives definite instructions for doing the various rewinding jobs. Also gives many data, tables and diagrams constantly needed by the repair man, including data difficult to get from any other sources.



Low price—easy terms—10 days' examination on approval

Bought separately the books in this Library would cost you \$11. By using this coupon you need pay only \$2.00 in 10 days and \$2.00 monthly until the special price of \$10.00 is paid. In addition, we give you 10 days in which to examine the books. Send no money; simply fill in and mail the coupon now; let us know your answer after you have seen the books.

McGraw-Hill Book Co., Inc., 350 W. 42nd St., N. Y. C.

Send Electric Motor Repair Library for 10 days' examination on approval. In 10 days I will send \$2.00, plus few cents postage, and \$2.00 monthly for four months, or return books postpaid. (We pay postage on orders accompanied by remittance of first installment.)

Name .....

Address .....

City and State .....

Position .....

Company .....

R.R. 12-36

## BUSINESS OPPORTUNITY

ACTIVE young radio mechanic, will make investment for expansion in established radio service shop metropolitan New York, EO-109, Radio Retailing, 330 West 42d Street, New York City.

## PHILCO SERVICEMAN and Catalog of PHILCO Parts and Tubes—Sent Free on Request.

WILLIAMS PHILCO., INC.  
800 S. Adams St. Peoria, Illinois

## UNUSUAL OPPORTUNITY

Radio-Appliance Salesman, with knowledge of retailer's problems to contact dealers throughout wide territories.

Liberal commission basis. Good income for hard workers. This is a cooperative plan now successfully operating for a very large number of dealers—unusual opportunity for dealer and salesman to substantially increase business and profits. Give details and territory desired in first letter. Must be free to travel and own car.

### NATIONAL COOPERATIVE STORES

47 Stanley Ave.  
Hastings-on-Hudson, New York

## FREE This Big New 1937 RADIO CATALOG

Thousands of Items—Latest Style Radio Sets—All at New Low Wholesale Prices . . .

Just off the press! One of the most complete radio catalogs ever published. Thousands of items—latest style radio receivers—nationally known radio parts—all at new, low wholesale prices. Sent to Radio Dealers and Service Men ONLY. Write today for your FREE copy.

SERVICE MEN'S RADIO SUPPLY CO.  
Dept. 1149, 2207 So. Halsted St., Chicago, Ill.



## 38 Amazing RADIOS



1937 Knight Radios offer you unbeatable profit-making opportunities! Sensational new features include giant 11-in. Magna-Span Diaphragm and super-dynamic Vita-Tone Speakers. Unmatched performance, at amazingly low prices. 38 models, 5-19 tubes, as low as \$8.45!

## 10,000 Service Parts

You can fill every service need from the ALLIED Catalog—at lowest prices. Lists over 10,000 exact duplicate and replacement parts, complete test equipment, tools, books, etc. You save time, trouble and money on every purchase by ordering from ALLIED.

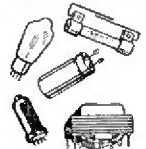

## Send For CATALOG

FREE!



This great 152-page Catalog also shows newest sound systems, amateur gear, kits, Ruripower units and Windchargers, etc. Whatever you need, you'll always find it in the ALLIED Catalog at the lowest prices.

## ALLIED RADIO

ALLIED RADIO CORPORATION Dept. 18-M  
833 W. Jackson Blvd., Chicago, Ill.

Send us your new 1937 Catalog (Free).

Name .....

Address .....

City .....



## Get This FREE RADIO CATALOG

Over 10,000 items in this big catalog including radio receivers, nationally known radio parts and broadcasting equipment at lowest wholesale prices. A catalog of great value to dealers and servicemen. Write today for your FREE copy of this big catalog.

BURSTEIN-APPLEBEE CO.  
1012-14 McGee St., Kansas City, Mo.

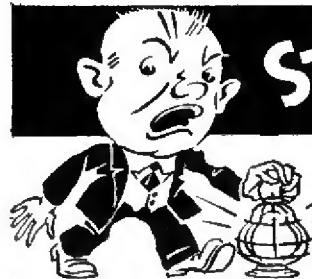

# STOP SEARCHING!

HERE IS YOUR "GUIDE"

## Don't Grope Around In The Dark . . . Send For This New Radio Buying Guide Today!

Here is the solution to all your radio supply problems . . . Here is your key to the fastest service . . . Lowest Prices . . . and the largest stock of Radio Repair Parts in the world! This Radolek new 1937 Radio "Profit Guide" is the most complete Radio Parts Catalog ever published . . . over 160 pages . . . bringing to you over 10,000 individual Repair Parts . . . hundreds of new items . . . a complete new selection of Radio Receivers, Amplifiers, Tubes, Tools, Books and Instruments . . . Everything you need . . . always in stock . . . ready for prompt shipment . . . at the right prices.

### YOU NEED THIS BIG CATALOG!

It's FREE! Send this coupon NOW! Radolek endeavors to restrict circulation of the Profit Guide to those actively engaged in the Radio business. Please enclose your business card or letterhead.



## RADOLEK

601 W. Randolph St., Dept. A-2, CHICAGO

Name .....

Address .....

Serviceman?  Dealer?  Experimenter?

## Rely on Radolek for "Everything in Radio"

FASTEST SERVICE

COMPLETE STOCKS

LOWEST PRICES

# LETTERS

## Troublesome Trade-Ins

The radio distributors and dealers in the Province of British Columbia have held a number of meetings for the purpose of discussing a plan whereby we could take off the market and destroy anywhere from three to five thousand small, obsolete sets which dealers get as trade-ins every year, most of which are kept in circulation regardless of the obvious fact that they should be destroyed.

The plan which seems to be the most feasible is to arbitrarily raise the list prices of all radio sets from \$5 to \$15, according to the value of the set, and use the money which would be received through this increase in price to create a fund, either to be administered as one general fund or by each distributor separately, wherewith to redeem from the dealers at a price of \$10 each radio set which is in the obsolete class. This would be mostly TRF sets.

Dealers tell us that even if they allowed \$20 for one of these sets they would be glad to turn it in to be destroyed if they received \$10 cash out of this fund, being further ahead to do this than to recondition the set and go to the expense of reselling it; and furthermore, they expressed a willingness to cooperate in getting these sets out of the way so that the market for new sets would be thereby enlarged.

VANCOUVER, B. C. W. C. CLARK  
*Western Agencies, Ltd.*

## Notes on Noise

Your article on radio noise in the October issue certainly hits the nail on the head and should do a great deal of good. The article covers the ground so thoroughly there is little I can add.

However, there is no question that interference is acting as a serious check on the sale of new radio sets. The records of various service departments would show that thousands of families are having their old sets repaired instead of buying new sets. They argue that these sets give them the principal programs and that the foreign programs they have heard in the homes of their friends, or of which they have heard, have been accompanied with too much noise to be satisfying.

When most of this noise is eliminated I believe the brakes on the sale of new sets will be released and the industry will go forward with leaps and bounds.

KANSAS CITY, MO. G. W. WESTON  
*Electric and Radio Ass'n of K. C.*

I just had an opportunity to read your article on radio noise. Although our interest is confined to the automobile field, as

an individual I am very much interested in radio generally, and you most certainly have struck upon the biggest weakness in the radio field today.

I've often wondered why the radio manufacturers did not take their coats off and go to work on this sadly neglected phase of radio. It seems untold amounts of money for research and production cost are available for all kinds of trick selling gadgets, tuning designs, etc., which are probably discarded within a year or two because of their impracticability, but the biggest source of irritation and dissatisfaction with the operation of radios—electrical interference—has reams of treatises written on the subject but practically nothing done to correct it.

DETROIT H. M. GOLDBOFF  
*Cadillac Motor Car Co.*

I have just had published in the "Letters" column of our local paper the story of what causes radio interference. Strange as it may seem, some people were greatly surprised to learn that their own appliances were causing much of it.

In one neighborhood alone we sold 7 radios after an offending factory cleared up noise. It cost him just \$17.20 to have his motors filtered.

All power companies will work on interference with dealers. May I suggest that other readers of *Radio Retailing* start stirring the subject up by writing to newspapers. I did it over the name "Fair Play," refraining from signing my name, so it could not in any way be construed as direct publicity for me.

DUBUQUE, IOWA FRED C. EVEN

We feel that your October article entitled: "Noise is Costing Us Money" deals with one of the greatest worries that station managers and radio receiver owners have today. If the manufacturers would only stop this radio interference from their appliances all radio stations and radio servicemen would rise up, call them blessed, and advise everyone to purchase the "noiseless" article.

SAN ANGELO, TEXAS EARLE YATES  
*Radio Station KGI*

## Sales Ammunition

Your page entitled "Why Good Service Can't Be Cheap" in the November issue is just about the best boost *Radio Retailing* has ever given the radio serviceman and the dealer.

I, as a serviceman, would like to use the entire page. Therefore, please write

me how I can obtain the printing mat of that page, the price, etc. If the mat cannot be obtained, let me know how I can get 1,000 copies of the above.

Articles of this type can educate the public as no other printed matter can.

ELIZABETH, N. J. HARRY MILLER

We'll gladly reprint this or any other page from any issue for our readers at cost. And we suspect that it would be difficult to do it cheaper locally even if cuts were available . . . which they usually are not due to other requests for reproductions.

EDITOR

## Good, As Advertised

I recently subscribed to your publication *Radio Retailing* and find it to be all you claimed.

Your book "Tricks of the Trade" has already helped me to make fast work of two jobs and the tips given were 100 per cent right.

BALTIMORE WILLIAM H. DEWHIRST

## \$18 Our Cost

Page 23 in the October issue of *Radio Retailing* ("Four Ways to Use Two Radios") appeals to us as an exceptionally good means of putting over an argument that every dealer should have, and one which may help to reduce the number of obsolete receivers on the retail market.

We would be pleased to distribute 2,500 copies of this page to our retail dealers throughout Canada if you could supply us with either reprints or tear sheets of that particular page.

Will you kindly advise us if you could supply these, also what you would charge us for the above mentioned quantity.

MONTREAL M. M. ELLIOTT  
*Canadian Marconi Company*

P.S. We've filled the order.

## Welcome

We are informed that a photograph that we supplied you showing a store display which this station made was published in *Radio Retailing*.

We would greatly appreciate a copy of this issue carrying the story and photograph. We think it was sometime in the summer.

We have today subscribed to *Radio Retailing* and will not miss anything further in your valued magazine.

GREENSBORO, N. C. EDNEY RIDGE  
*Radio Station WBIG*





The story this new G-E Radio window display tells is overflowing with human-interest. You'll find it a sure-fire magnet for drawing attention and directing "shoppers" into your store. Few displays have ever equaled its beauty of color and originality of composition. There is none that tells the quality story in so convincing a manner.

You can't miss the sales and profit momentum from gift purchases with this General Electric Radio gift-season display in your window. Use it to make your "store frontage" work double time to pull in prospects for demonstrations and sales. It's a "na-

ural" for the Xmas shopping season.

This eleven-color lithograph display is only one of a series of sales-promotion helps furnished to Authorized G-E Radio Dealers. The complete G-E Radio Sales-Promotion Service covers every sales-develop-

ment requirement that dealers need to direct their sales efforts more effectively and produce the most substantial results.

If you have not yet received your display—see your G-E Radio Distributor immediately.

**GENERAL  ELECTRIC**

AUTOMATIC

*Focused Tone Radio*

Appliance and Merchandise Dept., General Electric Co., Bridgeport, Connecticut.



# Nation-Wide Acclaim FOR CROSLEY'S BRILLIANT WORLD-WIDE RECEPTION

The whole country is talking about the perfect foreign and short wave reception of the new all-wave 1937 Crosley Radios. They're talking, too, about the exceptional Crosley features that make such fine reception possible—the famous Crosley Auto-Expressionator, Mystic Hand, Cardinamic Unit, Six-Step Fidelity Control and nine other outstanding improvements. With the holiday buying season about to begin you cannot afford not to sell this new 1937 Crosley Radio Line. Ask your Crosley Distributor to show you these sensational all-wave Crosley models and explain details of the Crosley Franchise.



**TABLE MODEL 744—7 Tubes**  
Continuous Coverage . . . 540-18,000 Kc. . . 5" Speaker . . . 5 Watts Output . . . Metal Tubes. Dimensions: 15½" high, 14" wide, 9" deep. . . . . **\$4995**

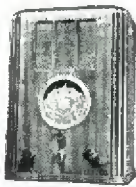

**TABLE MODEL 745—7 Tubes**  
Continuous Coverage . . . 540-18,000 Kc. . . 6" Speaker . . . 5 Watts Output . . . Metal Tubes. Dimensions: 20" high, 15½" wide, 9" deep. . . . . **\$4995**



**MODEL 649 CONSOLE—8 Tubes**  
American-Foreign . . . 540-1710 Kc., 4000-18,000 Kc. . . 12" Speaker . . . 5½ Watts Output. Dimensions: 30½" high, 23½" wide, 10½" deep. . . . . **\$5995**



**MODEL 759 CONSOLE—7 Tubes**  
Continuous Coverage . . . 540-18,000 Kc. . . 12" Speaker . . . 6 Watts Output . . . Metal Tubes. Dimensions: 40½" high, 24½" wide, 11½" deep. . . . . **\$6750**



**MODEL 769 CONSOLE—7 Tubes**  
Continuous Coverage . . . 540-18,000 Kc. . . 12" Speaker . . . 6 Watts Output . . . 6-Step Fidelity Control. Dimensions: 41½" high, 26" wide, 10" deep. . . . . **\$7995**

**AUTO-EXPRESSIONATOR**  
This exclusive Crosley feature restores to its original fullness the volume and expression range normally suppressed in broadcasting.

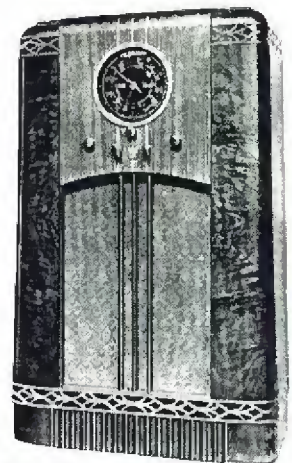

**MODEL 1516 CONSOLE—15 Tubes**  
Continuous Coverage . . . 540-18,000 Kc. . . 15" Curvilinear Speaker . . . 25 Watts Output . . . Auto-Expressionator . . . Mystic Hand . . . Cardinamic Unit . . . 6-Step Fidelity Control. Dimensions: 44½" high, 28" wide, 13½" deep. . . . . **\$17450**

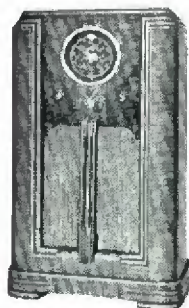

**MODEL 989 CONSOLE—8 Tubes**  
Continuous Coverage . . . 540-18,000 Kc. . . 12" Speaker . . . 12 Watts Output . . . Auto-Expressionator. Dimensions: 41½" high, 26" wide, 11½" deep. . . . . **\$9950**

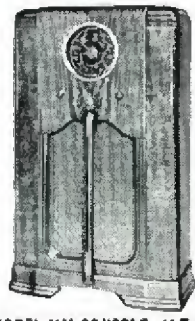

**MODEL 1139 CONSOLE—11 Tubes**  
Continuous Coverage . . . 540-18,000 Kc. . . 12" Speaker . . . 20 Watts Output . . . Auto-Expressionator . . . Mystic Hand. Dimensions: 51½" high, 27½" wide, 15½" deep. . . . . **\$10950**

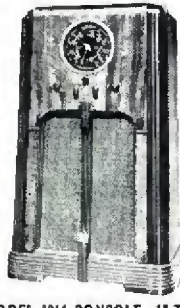

**MODEL 1211 CONSOLE—12 Tubes**  
Continuous Coverage . . . 540-18,000 Kc. . . 12" Speaker . . . 20 Watts Output . . . Auto-Expressionator . . . Mystic Hand. Dimensions: 42½" high, 26½" wide, 14" deep. . . . . **\$12950**

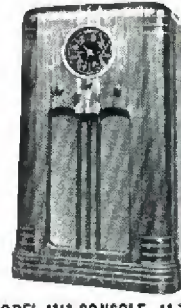

**MODEL 1313 CONSOLE—13 Tubes**  
Continuous Coverage . . . 540-18,000 Kc. . . 15" Speaker . . . 25 Watts Output . . . Auto-Expressionator . . . Mystic Hand. Dimensions: 43½" high, 27½" wide, 14" deep. . . . . **\$14950**

(Prices slightly higher in Florida, Rocky Mountain States and West.)

**THE CROSLEY RADIO CORPORATION, CINCINNATI** POWEL CROSLEY, Jr., President  
Home of WLW—the World's Most Powerful Broadcasting Station—70 on your dial

WHATEVER HAPPENS . . . YOU'RE THERE WITH A CROSLEY

# CROSLEY RADIO